

# Operating instructions

## CMVpro 125-400 ATEX

Centrifugal fan

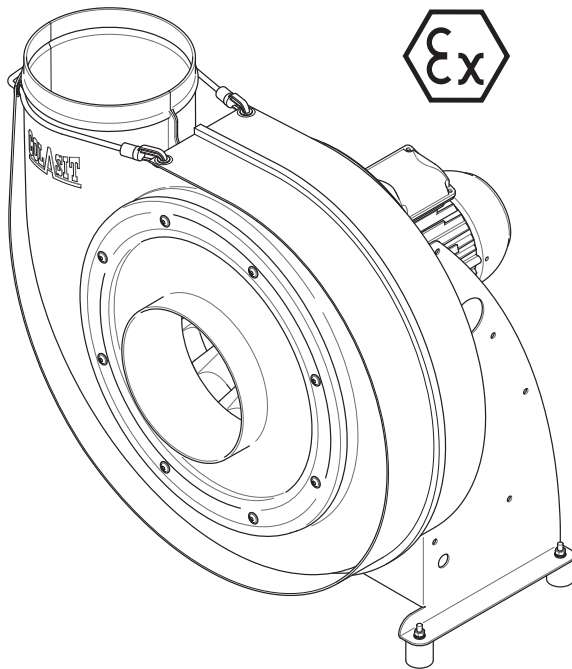

Your point of contact:

## Revision history table

Version		Description	Date	Name
1-en	EU/ATEX	First version published.	11/30/2021	A. Roth
1.1-en	EU/ATEX	Operating instructions revised.	11/25/2022	A. Roth

## Document identification

Translation of the original German operating instructions.  
Colasit TD-000828

## Contact information

### **Manufacturer**

COLASIT AG

Faulenbachweg 63

CH-3700 Spiez

E-mail: [info@colasit.ch](mailto:info@colasit.ch)

Phone: +41 (0)33 655 61 61

# Table of contents

<b>1</b>	<b>Operating instruction information .....</b>	<b>7</b>
1.1	Further applicable documents .....	7
1.2	Copyright .....	8
<b>2</b>	<b>Additional safety instructions .....</b>	<b>9</b>
2.1	Use and storage of the operating instructions .....	9
2.2	Intended application of the fan .....	9
2.2.1	Intended use .....	9
2.2.2	Reasonably foreseeable misuse .....	12
2.2.3	Equipment limits.....	12
2.2.4	Residual risks.....	13
2.3	Target groups and personnel requirements .....	14
2.3.1	Operator.....	14
2.3.2	Transport personnel.....	15
2.3.3	Mounting personnel .....	15
2.3.4	Operating personnel .....	16
2.3.5	Maintenance personnel.....	16
<b>3</b>	<b>Essential safety instructions .....</b>	<b>17</b>
3.1	Notation of safety instructions .....	17
3.2	Personal protective equipment .....	18
3.2.1	Personal protective equipment for potentially explosive environments .....	19
3.3	Mechanical hazards.....	19
3.4	Electrical hazards .....	20
3.4.1	Danger due to electromagnetic interferences .....	20
3.5	Explosion hazards .....	21
3.6	Thermal hazards.....	21
3.7	Noise hazard .....	21
3.8	Conveyed medium hazards.....	22
3.9	Dangers due to insufficient safety .....	22
3.10	Actions to take in an emergency .....	22
<b>4</b>	<b>Explosion protection.....</b>	<b>24</b>
4.1	Explosion protection measures .....	24
4.2	Explosion protection marking .....	25
<b>5</b>	<b>Structure and function.....</b>	<b>26</b>
5.1	Overview.....	26
5.2	Signs and warning symbols on the fan.....	27
5.3	Options and accessories .....	28
5.3.1	Vibration absorbers.....	28

5.3.2	Sleeves .....	29
5.3.3	Sleeves with flange .....	29
5.3.4	Flange connections .....	29
5.3.5	Condensate drain.....	30
5.3.6	Isolation switch.....	30
5.3.7	Frequency converter (FC).....	30
5.3.8	Speed adjustment potentiometer .....	31
5.3.9	Wall bracket .....	31
5.3.10	Motor cover .....	31
5.3.11	Protective grid .....	32
5.3.12	Hub seal felt ring .....	32
<b>6</b>	<b>Transport.....</b>	<b>33</b>
6.1	Safety instructions .....	33
6.2	Incoming goods inspection .....	33
6.3	Packing.....	34
6.4	Intermediate storage.....	34
6.5	Transport to installation location.....	34
6.5.1	Transport by crane.....	34
6.5.2	Transport by pallet stacker or forklift.....	35
<b>7</b>	<b>Mechanical installation .....</b>	<b>36</b>
7.1	Safety instructions .....	36
7.2	Installation location requirements .....	36
7.3	Splinter protection - check proper mounting .....	37
7.4	Vibration absorbers mounting.....	38
7.5	Foundation mounting.....	39
7.6	Wall mounting.....	39
7.7	Ceiling mounting.....	41
7.8	Connecting fan to ductwork .....	41
7.9	Connecting condensate drain to siphon .....	42
7.9.1	Siphon calculations and execution.....	43
7.10	Final inspection.....	44
<b>8</b>	<b>Electrical installation.....</b>	<b>45</b>
8.1	Safety instructions .....	45
8.2	Electrical protective devices .....	45
8.2.1	Isolation switch installation.....	45
8.2.2	Motor protection switch installation .....	46
8.2.3	PTC thermistor tripping device installation.....	46
8.2.4	Starting current limiter.....	47
8.3	Instructions for frequency converter (FC) use .....	47
8.3.1	Frequency converter (FC) installation options .....	48

8.3.2	Frequency converter (FC) parameterization .....	50
8.3.3	Connecting the electric motor to a frequency converter (FC) .....	50
8.4	Making ATEX-compliant ground connections.....	52
8.5	Connecting the electric motor .....	52
8.6	Mounting motor cover.....	54
8.7	Final inspection.....	54
<b>9</b>	<b>Placement in service .....</b>	<b>56</b>
9.1	Safety instructions .....	56
9.2	Carrying out placement in service .....	56
9.2.1	Check motor rotation direction .....	56
9.2.2	Functional test of the frequency converter (FC, optional accessory).....	56
9.2.3	Conduct test run.....	57
<b>10</b>	<b>Operation.....</b>	<b>59</b>
10.1	Safety instruction .....	59
10.2	Operating instructions.....	59
10.3	Outside cleaning.....	59
<b>11</b>	<b>Maintenance.....</b>	<b>60</b>
11.1	Safety instructions .....	60
11.2	Maintenance table .....	61
11.3	Maintenance work .....	61
11.3.1	Check operating condition .....	61
11.3.2	Inside inspection .....	62
11.3.3	Inside cleaning .....	62
11.3.4	Annual inspection.....	62
<b>12</b>	<b>Repair .....</b>	<b>64</b>
12.1	Safety instructions .....	64
12.2	Fault table.....	64
12.3	Spare parts and wear parts .....	69
12.4	Preparation for repairs.....	69
12.5	Impeller exchange .....	70
12.6	Casing exchange.....	72
12.7	Electric motor exchange .....	73
12.8	Check impeller.....	74
12.9	Hub seal (option) felt ring replacement.....	76
<b>13</b>	<b>Removal from service, disposal, and recycling .....</b>	<b>77</b>
13.1	Safety instructions .....	77
13.2	Environmental protection.....	77
13.3	Removal from service.....	77



---

13.4 Disposal instructions.....	78
<b>14 EU - Declaration of conformity.....</b>	<b>79</b>
<b>15 ATEX - Declaration of Conformity.....</b>	<b>80</b>
15.1 ATEX test report.....	82
<b>Index.....</b>	<b>83</b>

# 1 Operating instruction information

## Scope

These operating instructions provide qualified personnel with all essential safety instructions, information, and guidance for working with CMVpro 125-400 ATEX type centrifugal fans.

All phases of a centrifugal fan from transport, mounting, and placement in service to repairs and disposal are covered.

Careful reading of and compliance with these operating instructions will help to avoid injuries as well as environmental and material damage, ensure operational safety and reliability of the centrifugal fan, and minimize downtime.

## Storage location

The operating instructions and associated documents are to be stored near the centrifugal fan such that they are easily accessible to qualified personnel at all times.



The operating instructions and associated documents are also to be provided in electronic form upon delivery of the fan. This gives the operator the ability to print new operating instructions in the event that they go missing or to replace illegible or missing pages.

## Design notes

For the sake of simplification, in these operating instructions,

- the company Colasit AG is referred to as the “manufacturer,”
- the CMVpro 125-400 ATEX centrifugal fan is referred to as the “fan,”
- “frequency converter” is abbreviated as “FC,”
- chapter and page number references appear as follows: ⇒ Chap. 1 [▶ 7]

The images in these operating instructions are for illustrative purposes and could differ from the actual execution.

In the interest of our customers, we reserve the right to make changes as a result of technical developments.

## Translation note

The German language version of this document is the original set of operating instructions.

## Inquiries

If possible, clarify any ambiguities in a given language version with the aid of the original operating instructions. Ambiguities regarding the operating instructions are to immediately be clarified with the manufacturer. Placement in service of or other work on the fan is only permitted after successful clarification.

## 1.1 Further applicable documents

In addition to these operating instructions, the following documents and guidance shall be available as associated documents for working on the fan:

- Technical data sheet for the fan with complete technical data, including application limitations.
- Order confirmation or the specification sheet for the conveyed medium with information on the (limited) resistance of the fan to certain chemical substances. See also “Permissible conveyed media” ⇒ Chap. 2.2.1 [► 9].



The order confirmation also provides details regarding the full scope of delivery.

- Operating instructions for the electric motor.
- ATEX declaration of conformity for ATEX components: partly contained in separate operating instructions.
- Operating instructions for devices or equipment that were installed or included (e.g. FC or isolation switch).

#### **Additional document**

- Fan guideline FC/grounding/EMC/motors (EMC Guide) of the manufacturer, if the fan is intended for operation with a frequency converter (FC).

## 1.2 Copyright

These operating instructions are protected by copyright.

© COLASIT AG. All rights reserved.

The use and distribution of the operating instructions is permitted in the context of using the fan. Any other use is only permitted with the written consent of the manufacturer.



## 2 Additional safety instructions

This chapter contains information relevant to safety and additional as well as more in-depth safety instructions for operators and technical specialists.



### Additional safety instructions

Depending on the execution of the fan, associated documents can contain additional operating instructions with important safety instructions.

### 2.1 Use and storage of the operating instructions

- Before beginning mounting procedures or working on the fan, read these operating instructions carefully and completely.
- After use, always return the operating instructions to the marked storage location near the fan.

### 2.2 Intended application of the fan

The fan is intended for conveying gaseous media in potentially explosive atmospheres and is designed and manufactured in accordance with the state of the art and the recognized technical safety regulations.

Nevertheless, the fan may pose a danger to life and limb of personnel or third parties as well as material damage. Special care is therefore to be taken to ensure that the fan is in technically sound condition and that it is used as intended.

#### 2.2.1 Intended use

The fan is intended exclusively for the application specified on the nameplate and for installation in a complete system ⇒ Chap. 4.2 [▶ 25]. The fan may only be transported, mounted, and operated by trained qualified personnel with appropriate ATEX training/qualification ⇒ Chap. 2.3 [▶ 14].

#### Operating guidelines for potentially explosive atmospheres

The fan

- is suitable for conveyance of gases in zone 1 or 2 (equipment category 2 and 3), depending on the execution.

See fan nameplate ⇒ Chap. 5.2 [▶ 27] and ATEX Declaration of Conformity for this ⇒ Chap. 15 [▶ 80].

#### Permissible conveyed media

In general, conveyance of dust-free air is permissible within the parameters specified in the technical data sheet.

Conveyance of corrosive, hazardous, explosive, gaseous media is restricted as follows:

1. The following apply to a conveyed medium that is specified in the fan's technical data sheet:
  - The fan is suitable exclusively for conveyance of the specified medium.
  - The service life of the fan could be limited if there is a corresponding note in the order confirmation or the specification sheet.

2. The following apply to a conveyed medium that is specified as “undefined” in the fan's technical data sheet:
  - The fan is suitable for conveyance of corrosive, hazardous, explosive, gaseous media that fall under the explosion protection marking of the fan (explosion group, temperature class) and to which the plastics of the fan and the sleeves are resistant.
  - For independent assessment, the operator is to consult the pertinent available resistance lists for plastics. The SIMCHEM guide is found on the manufacturer's website ([www.colasit.ch](http://www.colasit.ch)).



The impeller, inlet cover, and housing of the fan are marked with an abbreviation for material identification (e.g. PPs-el for anti-static, electrically conductive plastic made of polypropylene).

- The order confirmation or the additional specification sheet contains further information and notes regarding a potential reduction in service life of the fan.
3. The following apply if, according to the operator's information, the conveyed medium contains several chemical substances:
    - The named importer or the manufacturer confirms the resistance of the fan to these chemical substances in the order confirmation or the specification sheet, which is an associated document.
    - The service life of the fan can be limited if there is a corresponding note in the order confirmation or the specification sheet.

### Permissible environmental conditions

1. The permissible operating and ambient temperature ranges are indicated on the fan nameplate.  
The minimum permissible operating temperature for the plastic parts of the fan is -20 °C.
2. The following applies if this information is missing from the nameplate:
  - Permissible ambient temperature range of the electric motor: See nameplate of the electric motor or the operating instructions/declaration of conformity of the motor manufacturer.
3. At operating temperatures below 4 °C, it is to be ensured by means of a constant minimum flow rate that
  - no condensate freezes in the fan or ductwork.
  - no pieces of ice from the ductwork get into the fan.

### Procedure for process changes

- The operator is to ensure upon a process change that
  - the fan can withstand the zone or parameters changed or the new conveyed medium,
  - the operating conditions according to the technical data sheet and nameplate plate are adhered to.

## Operating conditions

- The permissible operating conditions of the fan are defined by the parameters and limit values on the technical data sheet or on the nameplate of the fan and electric motor.

Note especially:

- Equipment category as well as ATEX certification of electric motor and accessories (FC, isolation switch, etc.) must be zone-compliant.
- The drive motor of the fan is designed for continuous operation (S1) or FC operation (S9).
- Maximum speed, which is dependent on
  - the temperature of the conveyed medium,
  - chemicals present and their concentration in the air stream.
- Prevention of excessive self-heating:
  - The operating point (see characteristic map on the technical data sheet) shall be above the minimum permissible conveyed volume.
- So that no or minimal conveyed medium escapes from the impeller hub,
  - operate the fan at a negative pressure,
  - or use a hub seal.
- The fan must be equipped with vibration absorbers ⇒ Chap. 7.4 [► 38].
  - Observe the permissible vibration limits according to standard values.
- The fan may not be mechanically stressed at the inlet and outlet connections.
  - Decouple the ductwork from the fan via the sleeves  
⇒ Chap. 7.8 [► 41].
- When using a frequency converter,
  - observe limit values for the acceleration time and braking time  
⇒ Chap. 8.3 [► 47],
  - the electrical connection to the motor is to be EMC compliant, with cable shield and grounding ⇒ Chap. 8.3.3 [► 50].
- Series or parallel operation of fans is permitted only after clarification and approval by the manufacturer or importer named in the operating instructions.

Intended use also includes compliance with all safety regulations and guidelines in these operating instructions.

## Maintenance and repair regulations

Adjustments and modifications to fans are strictly prohibited. Failure to comply will void ATEX conformity of the fan.



Only trained, qualified, and authorized personnel may perform work on explosion-proof fans.

## 2.2.2 Reasonably foreseeable misuse

Any use of the fan other than that for which it is intended or any other use is considered misuse and can lead to dangerous situations. The manufacturer assumes no responsibility for resulting injuries or material damage.

The following list of misuse is exemplary and not exhaustive.

- Conveyance of explosive dust.
- Operation in explosion protection zone 0 or in a zone that is not specified in the explosion protection marking on the nameplate of the fan or in the technical data sheet.
- Operation of the fan outside the parameters and limit values specified in the technical data sheet.
- Operation of the fan with prohibited conveyed media, such as solids and dust.
- Operation of the fan in spite of strong vibration or with disturbances that create an objectionable condition in terms of safety.
- Prohibited configurations of the frequency converter.
- Removal of components or tampering with components that ensure safe and proper function of the fan (e.g. vibration absorbers, splinter protection, sleeves, protective grid).
- Maintenance work conducted inappropriately, without ATEX training/qualification.
- Use of non-original spare parts.
- Explosion protection testing of the fan and system incomplete or not conducted.
- Unauthorized changes, modifications, or alterations to the fan.
- Any use of the fan that does not comply with the essential safety regulations of these operating instructions.
  - Operation without operating instructions and associated documents.
  - Operation with illegible or missing warning signs.

## 2.2.3 Equipment limits

### **Spatial dimensions**

The dimensions of the fan are specified in the technical data sheet.

### **Application limits**

The operating temperature range and further operating conditions are specified in the technical data sheet and on the nameplate.

### **Interfaces**

The fan has the following interfaces:

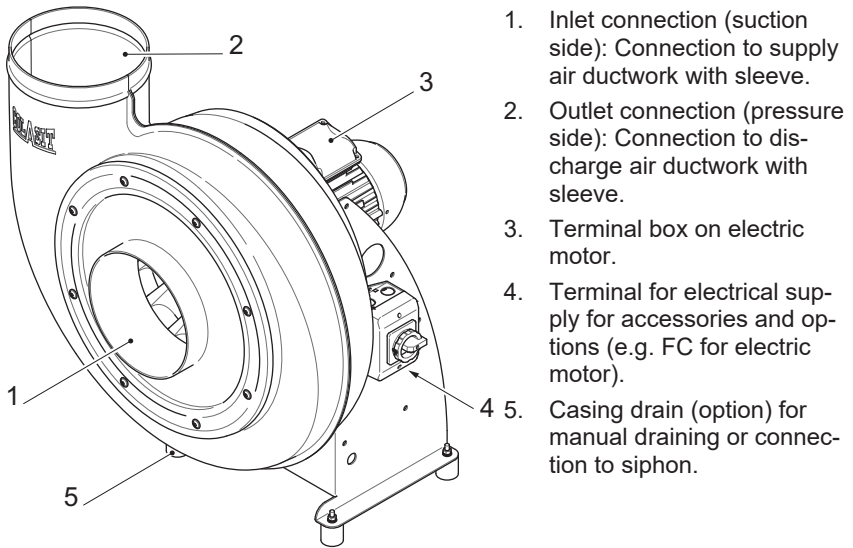

Fig. 1: Interfaces on fan

### Service life

The fan is designed for an expected service life of 15 years.

The motor bearings of quality motors are designed for a service life of 40,000 hours when used as intended.

The environmental, application, and operating conditions determine the service life of the hub seal (wear parts) of a given application.

## 2.2.4

### Residual risks

The fan is designed and manufactured in accordance with the state of the art and the recognized technical safety regulations. Residual risks nevertheless remain. They are indicated by safety instructions in these operating instructions and require the user to proceed with caution.

### Explosive, hazardous, aggressive conveyed media

Residue and deposits of the conveyed medium can reside in the fan or flow in from the ductwork.

- Qualified personnel responsible for maintenance and repair work shall
  - have appropriate ATEX training/qualification,
  - be trained in handling hazardous conveyed media,
  - wear suitable personal protective equipment ⇨ Chap. 3.2.1 [► 19],
  - coordinate with the operator when taking suitable protective and lock-out measures.

When operating the fan in an overpressure condition, the conveyed medium can escape at the impeller hub and lead to an explosion hazard and/or adverse health effects.

- When used with explosive and/or hazardous conveyed media, the fan is to be operated at a negative pressure or outfitted with the optional hub seal ⇒ Chap. 5.3.12 [▶ 32].

## 2.3 Target groups and personnel requirements

These operating instructions are intended for:

- The operator of the system in which the fan is installed.
- The qualified personnel who carry out work on the fan during its various life cycle phases, from installation to disposal.

The duties and personnel requirements for these target groups are described next.

### Requirements for staying and working in potentially explosive atmospheres

- Appropriate ATEX training/qualification required.
- Wear special personal protective equipment ⇒ Chap. 3.2.1 [▶ 19].
- Only use certified non-sparking equipment and tools in the explosion protection area.

#### 2.3.1 Operator

The operator is the person who operates the fan for commercial or economic purposes or who allows a third party to use it and who assumes legal liability during its operation.

The operator has the following duties:

For fan operation in potentially explosive atmospheres:



The classification and documentation of zones or definition of the equipment category in the system/installation.

Operate the fan only in zones for which the fan is approved.

- Comply with the minimum safety and health protection regulations for the use of work equipment and performance of activities on the fan.
- Keep current on national and local occupational safety and health regulations.
- Prepare Safety Data Sheets when the conveyed medium contains explosive and/or hazardous substances.
- Identify via risk assessment all additional dangers that arise due to special working conditions at the fan installation location.
  - Based on the risk assessment, derive, define, and implement for qualified personnel the appropriate protective measures and operating instructions for safe maintenance and other activities.
  - Adapt these operating instructions to current applicable standards and regulations at the time of operation.
- Ensure that the fan is always in a technically sound condition under observance of the maintenance intervals per these operating instructions.

- Initiate and verify that the function and integrity of all fan safeguards are checked regularly.
- Ensure that all manufacturer's regulations are observed upon retrofitting of safeguards.
- Determine the priority of shutting down the fan upon system malfunction or in an emergency.
- Clearly determine and regulate the responsibility for installation, servicing, maintenance, and repair of the fan.
- Ensure that the responsible qualified personnel
  - have read and understood these operating instructions,
  - have adequate occupational qualifications,
  - are regularly trained in the dangers related to and measures to take upon malfunction or in an emergency.
- Store these operating instructions and associated documents in their entirety in legible condition in an identified location near the fan.
- Save and protect the electronic version of these operating instructions.
- Prepare the required protective equipment and direct the wearing of this protective equipment by qualified personnel based on the operating and environmental conditions.

### 2.3.2 Transport personnel

The transport personnel are responsible for the transport of the fan to the installation location and for its removal for disposal at the end of its lifespan.

The transport personnel:

- Possess all necessary occupational knowledge, qualifications, and authorizations for operating the necessary lifting and transport devices.
- Are trained in the proper application of lifting and load handling attachments.
- Are knowledgeable of the safety and accident prevention guidelines and directives as well as recognized regulations of the technology applicable to transport.
- Are authorized by the operator to perform transport operations.

### 2.3.3 Mounting personnel

Mounting personnel are responsible for the installation of the fan in the system and for the subsequent placement in service. Removal of the fan for disposal also falls in this area of responsibility.

- Mounting personnel consist exclusively of qualified technical specialists who possess the necessary occupational experience, knowledge, and qualifications for mechanical and electrical work on the fan.
- The technical specialist is dependable when it comes to current safety and accident prevention guidelines, directives, and recognized regulations of the technology in their line of activity, and they are instructed by the operator.
- All work on the fan's electrical components may only be carried out by electricians.

- The fan may only be connected to the frequency converter by an electrician
  - after its operating instructions have been read and understood,
  - including detailed knowledge of the respective frequency converter,
  - and specialized knowledge of EMC-compliant wiring (consult the manufacturer's EMC guideline).
- The fan manufacturer's declaration of conformity is invalidated upon erroneous connection of the frequency converter and electric motor.

#### 2.3.4 Operating personnel

The fan is generally used in automatic operations with a controller.

If operating personnel are necessary, the operator ⇒ Chap. 2.3.1 [▶ 14] of the system is to determine the required education and qualifications for

- operating and outside cleaning of the fan ⇒ Chap. 10 [▶ 59].
- checking the operating condition of the fan ⇒ Chap. 11.3 [▶ 61].

#### 2.3.5 Maintenance personnel

Maintenance personnel are responsible for the inspection, cleaning, maintenance, and repair of the fan.

- The same requirements apply as for the mounting personnel  
⇒ Chap. 2.3.3 [▶ 15].
- An electrician is responsible for carrying out maintenance and repair work and for switching off and safely disconnecting the power supply from the fan.



## 3 Essential safety instructions

The associated documents can contain additional operating instructions with important safety instructions ⇒ Chap. 1.1 [▶ 7].

### 3.1 Notation of safety instructions

The safety instructions and warnings in these operating instructions are identified by the following warning symbols, signal words, and colors (electronic version of the operating instructions only), which convey the severity of the dangers.

#### Death or serious injuries

##### **DANGER** Danger to life due to... !



Outcome of the danger upon noncompliance...

- Conditions for prevention of the danger...
- ▶ Measures for prevention of the danger...

This safety instruction, the highest danger level, denotes a direct and immediate dangerous situation. This indicates a hazardous situation which, if not avoided, will result in death or serious injury.

#### Serious injuries

##### **WARNING** Risk of injury due to... !



Outcome of the danger upon noncompliance...

- Conditions for prevention of the danger...
- ▶ Measures for prevention of the danger...

A safety instruction of this danger level denotes a possible dangerous situation. This indicates a hazardous situation which, if not avoided, could result in death or serious injury with lasting effects.

#### Minor injuries

##### **CAUTION** Bodily injuries due to... !



Outcome of the danger upon noncompliance...

- Conditions for prevention of the danger...
- ▶ Measures for prevention of the danger...

A safety instruction of this danger level denotes a possible dangerous situation. This indicates a hazardous situation which, if not avoided, may result in minor or moderate injury, possibly with lasting effects.

#### Material damage

##### **NOTICE** Material damage due to... !



Outcome of the danger upon noncompliance...

- Conditions for prevention of the danger...
- ▶ Measures for prevention of the danger...

This warning instruction informs of a dangerous situation that can damage the fan or or lead to other material damage.

## 3.2 Personal protective equipment

The personal protective equipment to be worn:

- is to be determined and made available by the operator based on the operating conditions and conveyed medium.
- is the personal responsibility of the qualified personnel to be worn as suitable for the work to be conducted and to be supplemented as necessary.

The manufacturer recommends personal protective equipment according to the following table:

Symbol	Meaning
	Class 2 fluorescent warning vest with reflective stripes for improved visibility during transport operations.
	Close-fitting industrial safety clothing with low tear resistance for protection against introduction into rotating machinery.
	Hardhat to protect the head from falling objects, swinging loads, and strikes from sharp, pointed machine parts.
	Safety glasses to protect the eyes from airborne particles, parts, and fluids. Protection from aggressive, hazardous conveyed media or residues.
	Hearing protection required at or above noise exposure levels of 85 dB(A) or 137 dB (CPeak).
	Suitable breathing protection when in contact with aggressive, toxic conveyed media or residues.
	Work gloves for protection from injuries, burns, or contact with aggressive, toxic residues of the conveyed medium.
	Safety shoes for protection from crushing and from falling parts as well as slips and falls on slick surfaces.

### 3.2.1 Personal protective equipment for potentially explosive environments

It must be ensured for maintenance work on the fan in a potentially explosive environment that maintenance personnel are never dangerously electrostatically charged.

The following apply when in a potentially explosive environment:

- Personal protective equipment may not be changed, put on, or taken off.
- Wear conductive protective equipment (protective clothing, hardhat, gloves, and safety shoes).
  - The conductive properties may not be diminished through washing.
  - If potentially explosive areas are only entered temporarily, conductive shoe or boot covers may also be used.

### 3.3 Mechanical hazards

#### **⚠ DANGER** Risk of injury due to

- rotating impeller,
- parts ejected with high force following impeller breakage,
- sharp corners or edges.

Serious injuries due to debris being launched out.

Crush, cut, strike, eye, or other injuries.

- Operation in a manner other than intended (e.g. regarding temperature, speed, conveyed medium).
- ▶ Only authorized qualified personnel may conduct work on the fan.
- ▶ Prior to beginning mounting, maintenance, and repair work: Use the isolation switch to remove voltage on all phases.
- ▶ Prevent unauthorized start-up of the fan: Hang personal padlock and tag on isolation switch.
- ▶ Wear personal protective equipment.
- ▶ Do not leave any tools or mounting accessories in the fan.
- ▶ Comply with all current accident prevention guidelines.



#### **⚠ WARNING** Risk of injury due to automatic start-up

Entry and crushing of appendages.

- The fan is to be operated in a system and controlled by automatic controls.
- ▶ Prior to beginning mounting, maintenance, and repair work: Use the isolation switch to remove voltage on all phases.
- ▶ Prevent automatic start-up of the fan: Hang personal padlock and tag on isolation switch.



## 3.4 Electrical hazards

### **⚠ DANGER** Danger to life due to electric shock from contact with current-carrying conductors or components under hazardous voltage.

Immediate danger to life due to respiratory and cardiac arrest.

- Only a qualified and authorized electrician may work on the power mains and the electrical components of the fan.
- ▶ Prior to beginning mounting, maintenance, and repair work: Use the isolation switch to remove voltage on all phases.
- ▶ Prevent unauthorized start-up of the fan: Hang personal padlock and tag on isolation switch.
- ▶ Establish an electrically safe work condition before beginning work.
- ▶ Promptly rectify any defects discovered in the electrical components and wiring of the fan.
- ▶ Eliminate moisture from current-carrying components to avoid a short circuit.



### **⚠ WARNING** Risk of injury due to fire caused by short circuit

Burns, respiratory tract damage due to toxic fire smoke.

- ▶ Protect cables from mechanical, chemical, and thermal stresses.
- ▶ Regularly inspect the fan's electrical components. Replace damaged components and cables immediately.
- ▶ Have and periodically inspect suitable fire extinguishers. Observe the safety instructions on the fire extinguisher.



### 3.4.1 Danger due to electromagnetic interferences

Observe the following safety and hazard instructions if the fan is used with a frequency converter.

Frequency converters generate electromagnetic interference during operation and can cause high-frequency leakage current in the electric motor, supply power network, and grounding system.

#### **⚠ CAUTION** Interference from electromagnetic fields

Disturbance of sensitive electronic equipment by electromagnetic fields.

- ▶ When the fan is running, persons with pacemakers and other implanted electronic devices must not remain in the immediate vicinity of the frequency converter and electric motor.



#### **NOTICE** Disturbances to other devices from electromagnetic fields as well as bearing damage to electric motor due to leakage current

Exceeding legally permissible emission limits.

Reduced lifespan of the motor bearing.

Possible system operating faults and production interruptions.

- ▶ Use of suitable interference suppression and shielding methods, such as a mains suppression filter and shielded motor connection cable.
- ▶ EMC-compliant equipment design, especially for cable routing and shielding connections. See EMC Guide of the manufacturer and/or third-party equipment manufacturer.
- ▶ Observe FC manufacturer's recommendations for avoiding electromagnetic interferences.



## 3.5 Explosion hazards

### **DANGER** Danger to life due to ignition of explosive gas mixtures

Death or serious injuries if gas mixtures explode due to the following causes:

- Hot surfaces, such as frictional heat in hub seal or hot bearing surface of a defective motor bearing.
- Spark formation upon friction, impact, and grinding due to foreign bodies in the fan or a defective motor bearing.
- Spark formation due to electrostatic charge if the fan is not grounded or is grounded incorrectly.
- Spark formation due to leakage current induced in the motor bearings.
- ▶ Monitor ambient temperature or motor temperature and ensure sufficient cooling air supply.
- ▶ Check hub seal and motor bearing according to maintenance schedule.
- ▶ Protect fan against infiltration of foreign bodies (degree of protection at least IP 20 according to DIN EN 60529).



## 3.6 Thermal hazards

### **CAUTION** Risk of burn due to contact with hot surfaces

Burns to unprotected body parts.

- The fan housing and support can reach temperatures over 60 °C due to a hot conveyed medium.
- The fan's electric motor can reach temperatures over 60 °C on its surface during operation.
- ▶ Allow a hot fan or electric motor to cool off.
- ▶ Wear protective gloves when working on the fan or electric motor.
- ▶ When mounting the fan, observe the minimum distance between the fan cowl of the electric motor and neighboring components or walls  
⇒ Chap. 7.2 [▶ 36].



## 3.7 Noise hazard

### **CAUTION** High noise level with start-up and operation of the fan

Response upon being startled as well as hearing damage and hearing loss as long-term consequences.

- ▶ Observe the information in the technical data sheet on noise emissions from ducts and the casing.
- ▶ Wear hearing protection in the vicinity of the fan when required.
- ▶ Comply with legally mandated noise control regulations. If the fan is installed outdoors, comply with environmental noise emission limit values.



### 3.8 Conveyed medium hazards

**⚠️ WARNING Risk of injury due to escape or inflow of a conveyed medium with the ability to cause adverse health effects**

Risk of eye irritation, cough, difficulty breathing, burn, and suffocation.

- ▶ Clarify what medium is being conveyed.
- ▶ Observe the Safety Data Sheet(s) of the conveyed medium.
- ▶ Wear suitable personal protective equipment.
- ▶ Close the shut-off damper in the ductwork.
- ▶ Ventilate closed rooms.
- ▶ Take special safety precautions when working in confined spaces:
  - Request permit.
  - Inform supervisory personnel.
  - Assign an attendant.
  - Measure gas content in the work area.



**⚠️ WARNING Risk of injury due to aggressive, hazardous residue and deposits**

Chemical burn and poisoning upon contact.

- Conveyed medium forms deposits in the fan and ductwork that can cause adverse health effects.
- ▶ Wear suitable personal protective equipment.
- ▶ Observe the Safety Data Sheet(s) of the conveyed medium.
- ▶ For leaking condensate: neutralize, immediately wipe up, and dispose of in accordance with current local regulations.



### 3.9 Dangers due to insufficient safety

**⚠️ WARNING Risk of injury due to missing or non-functioning safeguards**

- Safeguards on fan: Isolation switch, splinter protection, protective grid for free sucking/blowing installation.
- ▶ Regularly inspect safeguards for function and damage.
- ▶ Replace missing or damaged safeguards immediately.



### 3.10 Actions to take in an emergency

Explosion or melting of the plastic components during fan operation constitutes an emergency situation.

Possible causes (due to use in a manner other than that intended):

- Mechanical damage to the impeller due to foreign objects or speeds above the permissible limit.
- Prohibited chemical or thermal factors (compare with technical data sheet).

Possible consequences:

- Parts ejected from the fan with high force.
- Casing explosion.
- Escape of conveyed medium.
- Development of hot, corrosive, hazardous, or flammable gases.

**⚠️ WARNING Risk of injury due to damaged fan**

- Fan can continue coasting for a long time after being switched off.
- Danger by contact with dangerous parts and conveyed medium if casing is damaged.
- ▶ Use caution when approaching the fan.
- ▶ Observe the Safety Data Sheet(s) of the conveyed medium.

If no emergency measures are directed by the operator, proceed as follows:

1. Use the isolation switch to remove voltage on all phases.
2. Get personnel who are injured or in danger to safety. Get personnel who are having difficulty breathing to fresh air immediately.
3. Perform first aid.
4. Alert rescue/emergency personnel and inform them of the hazards of the conveyed medium according to the Safety Data Sheet.
5. Safeguard the hazardous area.
6. Fight small incipient fires only with fire extinguishers approved for low-voltage electrical equipment and the conveyed medium.

**⚠️ WARNING Risk of burn, risk of poisoning from smoke inhalation**

Burns, damage to respiratory tract.



- The thermoplastic of the fan generates smoke when burnt.
- If the fan housing is made of PVC, there will be adverse health effects and caustic smoke when burnt.
- ▶ Maintain a safe distance when extinguishing.
- ▶ Pay attention to the direction in which the smoke is spreading.

**⚠️ WARNING Danger of asphyxiation with carbon dioxide (CO<sub>2</sub>) fire extinguisher use**

- There could be a high concentration of carbon dioxide (CO<sub>2</sub>) in the breathing air.
- ▶ Do not attempt to extinguish in confined, small, or enclosed spaces.
- ▶ Instead, fight fire from outside through open door.
- ▶ Do not access area where fire occurred until it has been thoroughly ventilated.

## 4 Explosion protection



The zone of the conveyed medium and the installation site are to be specified by the system operator when ordering the fan.

### Explosion protection information

- Intended use and operating conditions ⇒ Chap. 2.2.1 [► 9].
- The fan is approved for conveyance of gases in zone 1 or 2 (equipment category 2 and 3).
- **The fan is not approved for explosion protection zone 0 (equipment category 1).**
- The fan is approved for temperature classes T3 or T4.
- Parameters and limit values according to technical data sheet.



In addition to these operating instructions, additional ATEX information on the design and operation of fans is available from the point of contact.

### 4.1 Explosion protection measures

An ignition hazard assessment has been carried out by the manufacturer in accordance with the requirements of Directive 2014/34/EU (ATEX).

The operating instructions contain important instructions regarding explosion protection measures:

- General hazards ⇒ Chap. 3.5 [► 21].
- Thermal motor protection ⇒ Chap. 8.2 [► 45]/⇒ Chap. 8.2.3 [► 46].
- Grounding ⇒ Chap. 8.4 [► 52].
- Use of a frequency converter ⇒ Chap. 8.3 [► 47].
- Operation ⇒ Chap. 10 [► 59].
- Maintenance and explosion protection testing ⇒ Chap. 11 [► 60]



## 4.2 Explosion protection marking

The explosion protection marking is located on the nameplate of the fan  
 ⇒ Chap. 5.2 [► 27] and classifies the fan for use in a potentially explosive atmosphere ⇒ Chap. 15 [► 80].

### Explosion protection marking example

CE	UK CA	⊕ Ex	II 2/3G	Ex h IIB+H2 T3 or T4 Gb/Gc	Droplets excluded
		Directive section	Standards section		Addendum

Symbol/ Code	Description
CE	CE mark
UK CA	UKCA mark
⊕ Ex	Explosion protection marking according to Directive 2014/34/EU (ATEX).
II	Equipment group
2/3G	Equipment category inside (2)/outside (3) the fan for gaseous conveyed media (G).
Ex h	Explosion protection (Ex) through protection type (h): Explosion protection through design safety.
IIB+H2	Explosion group: Equipment group (II) for electrical devices with gaseous media and hydrogen (B+H2)
T3	Temperature class for 200 °C max. surface temperature.
Gb/Gc	Equipment protection level (EPL) inside/outside of fan: Gas (G), protection level (b) for equipment category 2 (zone 1, 2), Gc for equipment category 3 (zone 2)
Droplets	Addendum only for the case that droplets in the conveyed medium are excluded.



The nameplate of the electric motor also contains information on explosion protection, such as temperature class and protection type.

## 5 Structure and function

### 5.1 Overview

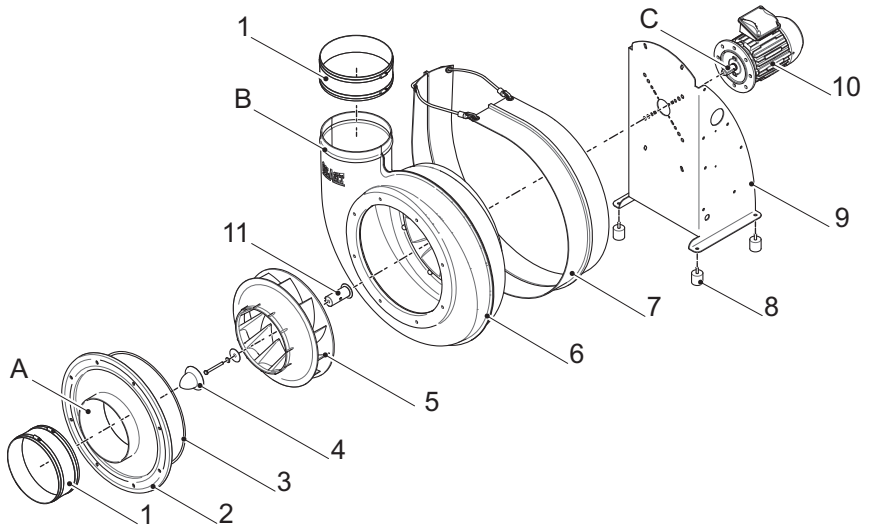

Fig. 2: Fan overview

- 1 Sleeve (2x) in zone-compliant Ex execution: Stress-free connection of the inlet (A) and outlet (B) connections to the connection tubes.
- 2 Inlet cover, removable: Directs the conveyed medium through the inlet connection (A) into the fan. Serves as maintenance opening.
- 3 Sealing ring: Seals inlet cover (2) to casing (6).
- 4 Hub cap: Seals hub adapter (11) and motor shaft (C) from contact with the conveyed medium.
- 5 Impeller in zone-compliant ATEX execution: Backward curved impeller blades, balanced, balancing quality G6.3 according to ISO 21940-11.
- 6 Casing in zone-compliant ATEX execution
- 7 Splinter protection: Prevents fragments from being ejected in the event of impeller breakage.
- 8 Vibration absorber: Absorbs damaging vibration and serves for fastening the fan.
- 9 Support
- 10 Electric motor in zone-compliant ATEX execution
- 11 Hub adapter: Interlocks the impeller (5) with the motor shaft (C).

#### Function description

In the centrifugal fan, a gaseous medium is drawn in through the inlet connection in the direction of the motor axis and deflected radially by the rotating impeller.

The mechanical energy supplied by the electric motor causes an increase in pressure and speed of the conveyed medium. The spiral-shaped casing directs the conveyed medium to the outlet connection.

## 5.2 Signs and warning symbols on the fan

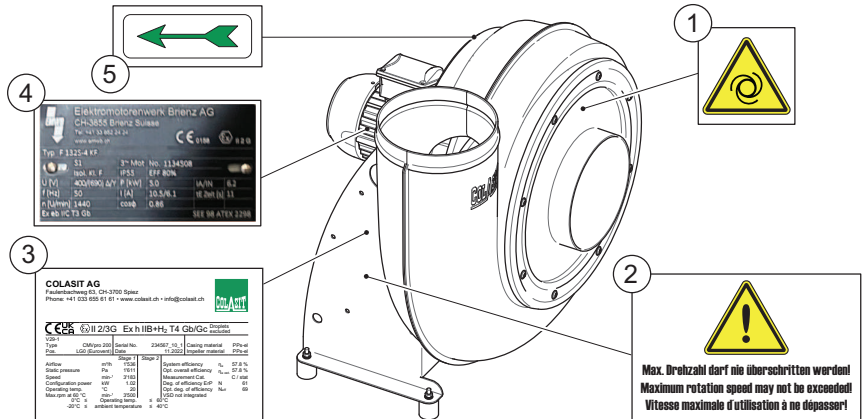

Fig. 3: Signs and warning symbols on the fan

- |                                     |                               |
|-------------------------------------|-------------------------------|
| 1 “Automatic start-up” warning sign | 4 Electric motor nameplate    |
| 2 “Maximum speed” warning sign      | 5 Direction of rotation arrow |
| 3 Fan nameplate                     |                               |



For FC operation, the nameplate or a supplementary nameplate of the electric motor contains additional information on limit values according to EN 60079-7 (max. frequency [ $f_{max}$ ] and other information).

The operator's responsibilities regarding these signs on the fan are to

- keep them clean and uncovered,
- replace them if damaged or missing.

## 5.3 Options and accessories

### 5.3.1 Vibration absorbers

#### Vibration absorbers for floor wall mounting

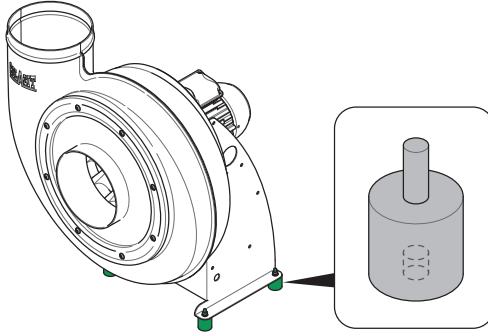

- **Required accessory.**
- For mounting the fan on the floor ⇒ Chap. 7.5 [▶ 39] or on a wall bracket ⇒ Chap. 7.6 [▶ 39].
- Dampens vibration and prevents operating faults.
- Designed for permissible fan vibration according to ISO 14694.

Fig. 4: Vibration absorbers for floor and wall mounting

#### Vibration absorbers for ceiling mounting

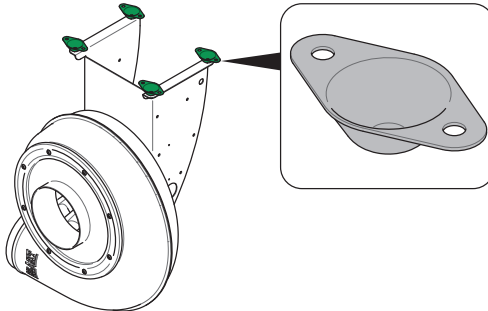

- **Required accessory.**
- For ceiling mounting of the fan (can handle tensile load).
- Dampens vibration and prevents operating faults.
- Designed for permissible fan vibration according to ISO 14694.

Fig. 5: Vibration absorbers for ceiling mounting



Instructions for vibration absorber selection and item characteristics  
⇒ Chap. 7.4 [▶ 38].

### 5.3.2 Sleeves

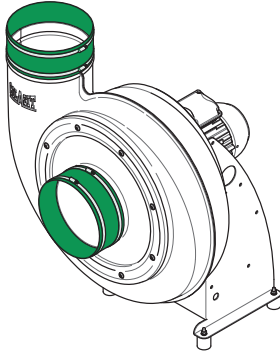

- **Required accessory.**
- Wellflex sleeve made of electrically conductive material for zone 1 (equipment category 2 and 3). In zone 2, standard execution.
- For flexible connection of the inlet and outlet connections to straight ductwork.
- Sleeves inhibit the transfer of mechanical loads to the fan housing.
- Attach with hose clamps.
- Executions: See CMVpro accessories on the manufacturer's website ([www.colasit.ch](http://www.colasit.ch)).
- Permissible distance between fan connection and ductwork ⇒ Chap. 7.8 [► 41].

Fig. 6: Sleeve installation locations

### 5.3.3 Sleeves with flange

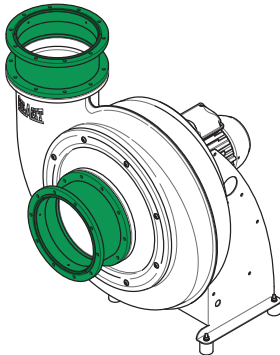

- **Required accessory for fans with flange connections.**
- Wellflex sleeve made of electrically conductive material for zone 1 (equipment category 2 and 3). In zone 2, standard execution.
- For flexible connection of the inlet and outlet connections to ductwork with flange connections.
- Executions: See CMVpro accessories on the manufacturer's website ([www.colasit.ch](http://www.colasit.ch)).

Fig. 7: Sleeves with flange

### 5.3.4 Flange connections

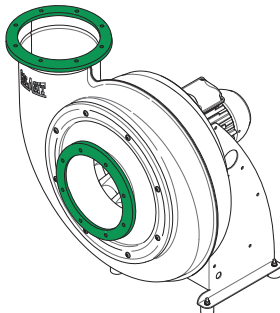

- Optional.
- Inlet and outlet connections with flange connection.
- Executions: See CMVpro accessories on the manufacturer's website ([www.colasit.ch](http://www.colasit.ch)).
- Sleeves with flange required  
⇒ Chap. 5.3.3 [► 29].

Fig. 8: Flange connections

### 5.3.5 Condensate drain

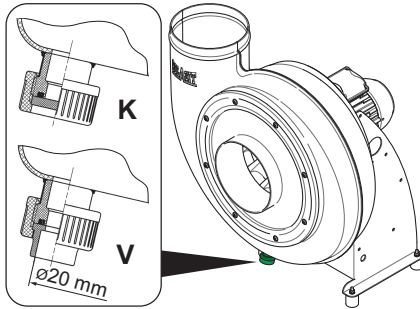

- Optional.
- For draining of condensate.
- Executions:
  - “K” for manual draining with cover cap.
  - “V” for connection to siphon. Suitable for socket welds.
- For instructions on retroactive mounting as well as siphon dimensioning ⇒ Chap. 7.9 [▶ 42].

Fig. 9: Casing drain on condensate drain

### 5.3.6 Isolation switch

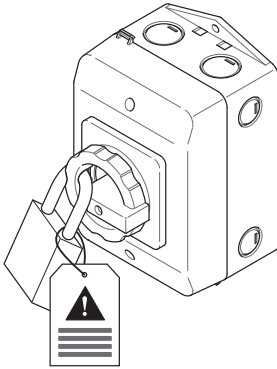

- **Required accessory.**
- In zone-compliant ATEX execution.
- For removal of voltage on all phases before maintenance and repair work.
- Can be locked in the OFF position with a customer-supplied padlock.
- Note: The isolation switch is also referred to as a maintenance switch.

Fig. 10: Isolation switch

### 5.3.7 Frequency converter (FC)

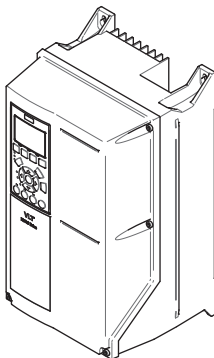

- Optional accessory.
- Mounting outside of ATEX zone.
- For fan speed control.
- FC installation options ⇒ Chap. 8.3.1 [▶ 48].
- EMC-compliant wiring ⇒ Chap. 8.3.3 [▶ 50].
- FC parameterization ⇒ Chap. 8.3 [▶ 47].
- With connection for PTC thermistor tripping device or integrated PTC thermistor monitoring ⇒ Chap. 8.2.3 [▶ 46].

Fig. 11: Frequency converter (example)

### 5.3.8 Speed adjustment potentiometer

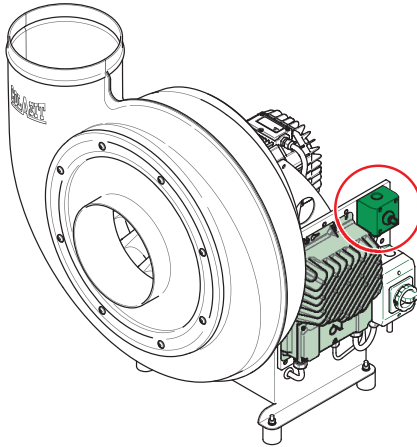

- Optional accessory.
- Only applicable if inside is ATEX zone 2 and no ATEX zone outside.
- For setting the nominal speed on the frequency converter (FC) according to the technical data sheet.
- FC parameterization  
⇒ Chap. 8.3 [▶ 47].

Fig. 12: Potentiometer with frequency converter (example)

### 5.3.9 Wall bracket

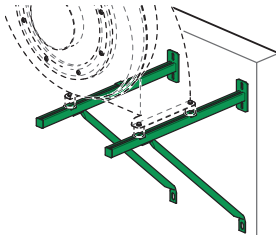

- **Required accessory for wall mounting.**
- Executions: See accessories for the CMVpro 125 - 400 on the manufacturer's website ([www.colasit.ch](http://www.colasit.ch)).
- For mounting instructions ⇒ Chap. 7.6 [▶ 39].

Fig. 13: Wall bracket

### 5.3.10 Motor cover

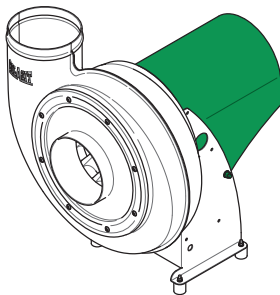

- Optional accessory able to be retrofitted.
- Made of material that conforms to zone.
- Protects electric motor or electric motor with attached FC (accessory) from the weather.
- For mounting instructions ⇒ Chap. 8.6 [▶ 54].

Fig. 14: Motor cover

### 5.3.11 Protective grid

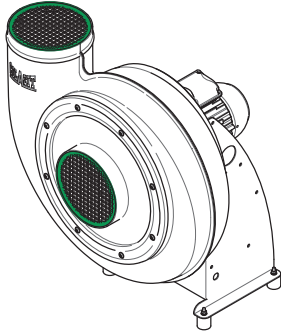

- **Required accessory for free sucking and/or blowing installation**, as access and safety protection.
- Made of material that conforms to zone.
- Gets permanently installed (welded) to the free-sucking inlet connection and/or to the blowing outlet connection.
- Entry protection as well as protection against infiltration of contamination and foreign objects (IP20 degree of protection).
- **NOTICE** Protective grid not suitable for connection to ductwork (increased pressure loss).

Fig. 15: Protective grid

### 5.3.12 Hub seal felt ring

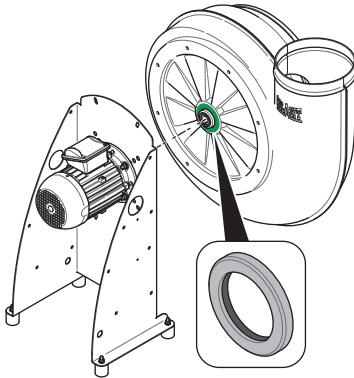

Fig. 16: Hub seal felt ring

- Optional.
- Use with hazardous, aggressive conveyed media when the fan is operated in an overpressure condition.
- Wear part
- For mounting instructions, see ⇒ Chap. 12.9 [► 76].



## 6 Transport

### 6.1 Safety instructions

These safety instructions warn against dangers that can arise when transporting the fan.

#### **⚠️ WARNING** Danger to life when remaining under suspended loads

Injuries due to falling or swinging loads.



- ▶ Avoid hazardous area under the suspended load.
- ▶ Never stand under or in swinging range of suspended loads.
- ▶ Maintain a safe distance from suspended loads.
- ▶ Do not leave suspended loads unattended.

#### **⚠️ WARNING** Risk of injury due to packing pieces falling or tipping over

Bruising and contusion injuries.

#### **SAFETY INSTRUCTIONS**



- ▶ Wear personal protective equipment.
- ▶ Only use hoisting gear, load handling attachments, and slings that are undamaged, approved, and have suitable load-bearing capacity.
- ▶ Use all attachment points provided, and observe the center of gravity ⇒ Chap. 6.5.1 [▶ 34]. Exception: **The lifting eye bolt on the electric motor is not an attachment point for transport.**
- ▶ Do not place slings on sharp edges or corners, and do not knot or twist them.
- ▶ The transport route must be free of obstacles and safeguarded in accordance with local regulations.

#### **NOTICE** Risk of damage due to improper transport

Damage to the fan and other material damage.



- A package with a center of gravity that is off center can tip, swing out, or fall down when lifted.
- ▶ Use provided attachment points.
- ▶ Use additional transport aids as transport protection.
- ▶ Lift package cautiously.
- ▶ Avoid rocking and swinging movements during transport.

### 6.2 Incoming goods inspection

For the delivered fan:

- Check for completeness based on the shipping documents.
- Inspect for possible transport damage.

If transport damage is detected:

1. Do not receive delivery, or doing so only conditionally.
2. Record transport damage (photos).
3. Note the extent of the damage on the transport paperwork or on the transport company's bill of lading.
4. File a complaint immediately.



Claims for damages can only be made within the complaint period and according to the general terms and conditions (T&C). Save packing for a possible return shipment.

5. Mount fan and place in service only after repairs and resolution of complaints.

## 6.3 Packing

The packing and provided transport protection protect the fan from transport damage and environmental influences.

Do not damage the packing, and remove it only shortly before mounting.



### Disposal instructions

The transport packing is intended as disposable packing and is to be disposed of after use according to current local disposal instructions.

## 6.4 Intermediate storage

Pack the fan in the original packaging as follows:

- Covered, dry, and dust-free location.
- Protect from sun, weather, and condensation.
- Storage temperature +10 °C to +50 °C with max. 50 % humidity.

### Measures for longer intermediate storage

After every 3 months of storage time, turn the impeller several rotations to prevent bearing damage.

## 6.5 Transport to installation location

Provide suitable hoisting gear and load handling attachments for transport.

### 6.5.1 Transport by crane

#### Transporting package with lifting eye bolts

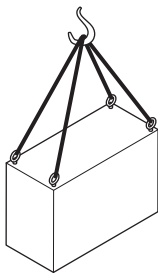

- Position crane hook over the middle of the package.
- Attach sling to all lifting eye bolts of the packing.
- **WARNING** Do not lift the fan by the lifting eye bolt of the electric motor.
- Check: Slings are not twisted. Sling legs and bends are in permissible positions.
- Lift package slightly and check that it hangs level.

Fig. 17: Package with lifting eye bolts

- Let down and adjust a package that doesn't hang level: Shorten or lengthen legs on one side appropriately until all legs are loaded equally.

### Transporting package on a pallet

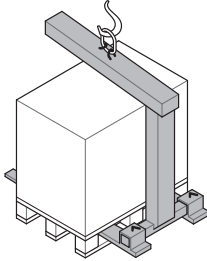

- Inspect pallet: A damaged or rotted pallet may not be transported by crane.
- Preferably, transport pallet by crane fork or pallet jack.
- Otherwise, attach sling to pallet such that it will not slip.
- Further procedure same as for as transport with lifting eye bolts.

Fig. 18: Package on transport pallet

### Transporting fan with chain sling

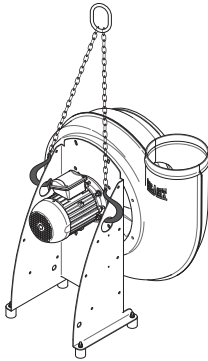

To transport an unpacked fan, use a two-leg chain sling.

- Hang chain sling as illustrated in the two large holes in the support.
- ⚠ WARNING** Do not lift the fan by the lifting eye bolt of the electric motor.
- Further procedure same as for as transport with lifting eye bolts.

Fig. 19: Fan with chain sling

## 6.5.2 Transport by pallet stacker or forklift

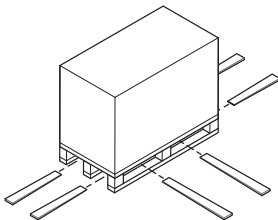

A package on a pallet can be transported by pallet stacker or forklift under the following conditions:

- Forks inserted under the pallet as depicted such that they stick out from the opposite side.

Fig. 20: Package on transport pallet

## 7 Mechanical installation

### 7.1 Safety instructions

These safety instructions warn against dangers that can arise when mounting the fan.

#### **⚠️ WARNING Risk of injury due to unsecured work area**

Injuries due to objects falling or being bumped.

- The installation location of the fan could be inaccessible or at a dangerous height.
- ▶ Set up safe means for accessing the installation location (e.g. walkway with banisters, platform).
- ▶ Safeguard work area with enclosures, safety nets, etc.
- ▶ Secure work area against unauthorized access.



#### **⚠️ WARNING Risk of injury due to improper mounting**

Injuries by pinching and crushing of body parts.

- ▶ Find out from structural or construction engineer:
  - Foundation (baseplate) - execution and load capacity.
  - Fastening elements for wall bracket, ceiling mounting.
- ▶ Safeguard fan against tipping by suitable means.
- ▶ Immediately following completion of mounting work, remove all braces, supports, etc.



#### **⚠️ WARNING Risk of injury due to escape or inflow of a conveyed medium with the ability to cause adverse health effects**

Risk of eye irritation, cough, difficulty breathing, burn, and suffocation.

- ▶ Wear protective equipment.
- ▶ Close shut-off damper to inlet and outlet connections until all installation work is complete.
- ▶ Watch for escaping conveyed medium as well as deposits and condensate when using the service opening and inspecting the ductwork.



### 7.2 Installation location requirements

#### **📢 NOTICE Risk of damage due to improper outside mounting**

Material damage and production downtime.

- ▶ Protect fan and FC (option) from exposure to weather as much as possible (e.g. with motor cover ⇒ Chap. 5.3.10 [▶ 31]).
- ▶ Use platform for installation sites with poor drainage.



Foundation (baseplate) or mounting surface shall meet the following requirements:

- Vibration resistant
- Flat surface
- Suitable for absorption of static and dynamic loads.
  - For calculations for the mounting parts, assume four times the fan weight.

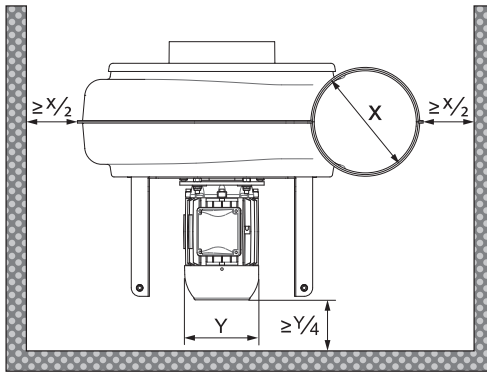

- Provide suitable clearance around the fan for
  - maintenance and repair work,
  - motor cooling.

Fig. 21: Space requirement for work area and motor cooling



### Dimensioning notes

The minimum distance at the installation site for the fan cowl of the electric motor must be larger than one fourth the diameter (Y) of the fan cowl.

## 7.3 Splinter protection - check proper mounting

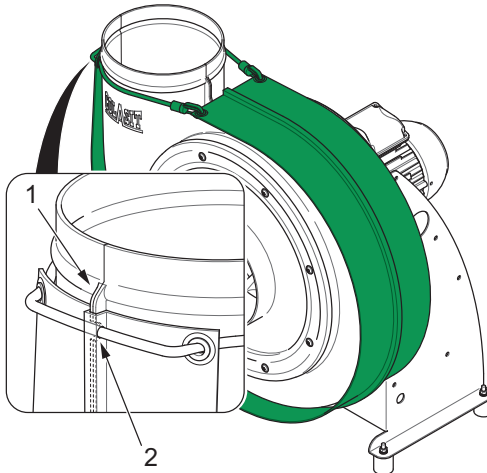

Check proper mounting of the splinter protection:

- The groove in the splinter protection lies along the welding edge (1) of the casing.
- The rubber band lies in notch (2) on the welding edge.
- Snap hooks are hooked through the eyelets.

Fig. 22: Proper mounting of the splinter protection

## 7.4 Vibration absorbers mounting

### **⚠ WARNING** Risk of injury due to fan falling down or falling over

Injuries by pinching and crushing of body parts.



- Undersized vibration absorbers can come off.
- Ceiling-mounted vibration absorbers shall be able to handle tensile load and may not loosen with vibration.
- ▶ Use the supplied vibration absorbers.
- ▶ Externally sourced vibration absorbers shall be equivalent.
- ▶ Only replace vibration absorbers with equivalent components during maintenance work.

### **NOTICE** Risk of damage due to vibration



Material damage and production downtime, reduced service life.

- Missing or improperly sized vibration absorbers lead to damage of the motor, impeller, and installation site.
- ▶ Always mount fan with suitable vibration absorbers.
- Mount suitable vibration absorbers on the mounting holes of the support.
- Select the vibration absorbers according to the following table in consideration of the installation position and the size or total weight of the fan  
⇒ Chap. 5.3.1 [▶ 28].

#### Suitable vibration absorbers for floor/wall mounting

Fan/size	Type for floor/wall mounting	Connection thread	Load capacity [kg/pc]	Shore hardness [A]	Quantity [pc]
CMVpro 125-200	V 8/30	M8 x 20	50	68	4
CMVpro 250-400	V 8/40	M8 x 23	88	68	4

#### Suitable vibration absorbers for ceiling mounting

Fan/size	Type for ceiling mounting	Connection thread	Load capacity [kg/pc]	Shore hardness [A]	Quantity [pc]
CMVpro 125-200	G-E-06	M6	16	55	4
CMVpro 250-400	G-E-10	M10	50	55	4

## 7.5 Foundation mounting

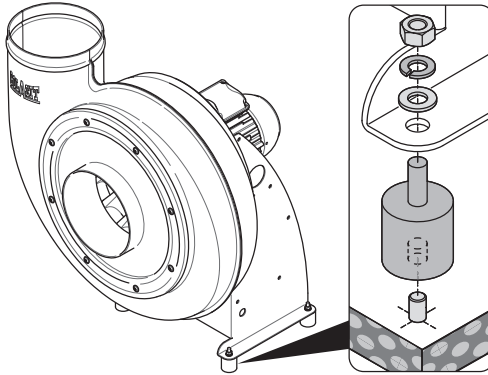

Conditions:

- Installation location requirements ⇒ Chap. 7.2 [▶ 36].
- Fastening elements present.

Fig. 23: Fastening recommendation for floor mounting

1. Transfer fan support hole pattern to the foundation (baseplate).



Hole pattern dimensioning according to technical data sheet.

2. Install anchoring elements (anchors) according to supplier's instructions.
3. Fix vibration absorbers to anchoring elements.
4. Set fan on vibration absorbers and fasten tightly.

## 7.6 Wall mounting

### **⚠ DANGER** Risk of injury due to fan falling over

Injuries by pinching and crushing of body parts.



- Never mount fan support vertically on the wall!
- ▶ Only mount fan with wall bracket ⇒ Chap. 5.3.9 [▶ 31].
- ▶ Tightly screw in and secure all screw connections.

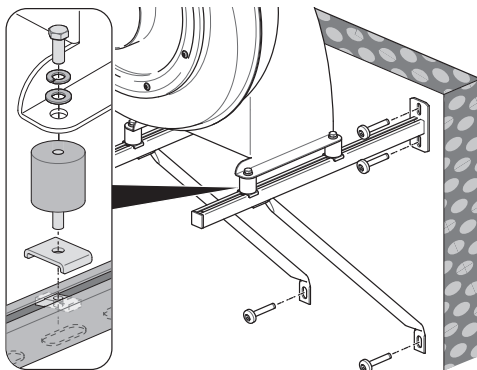

Conditions:

- Installation location requirements ⇒ Chap. 7.2 [▶ 36].
- Wall bracket shall be designed for four times the fan weight.
- Fastening elements present.

Fig. 24: Fastening recommendation for wall mounting

1. Transfer hole pattern from wall bracket with support braces to wall.
2. Install anchoring elements (anchors) according to supplier's instructions.
3. Fix wall bracket to wall with support braces (at 45° bracing angle).
4. Pre-assemble vibration absorbers to wall bracket.
5. Set fan on vibration absorbers and align and fasten per dimension H of the following table.

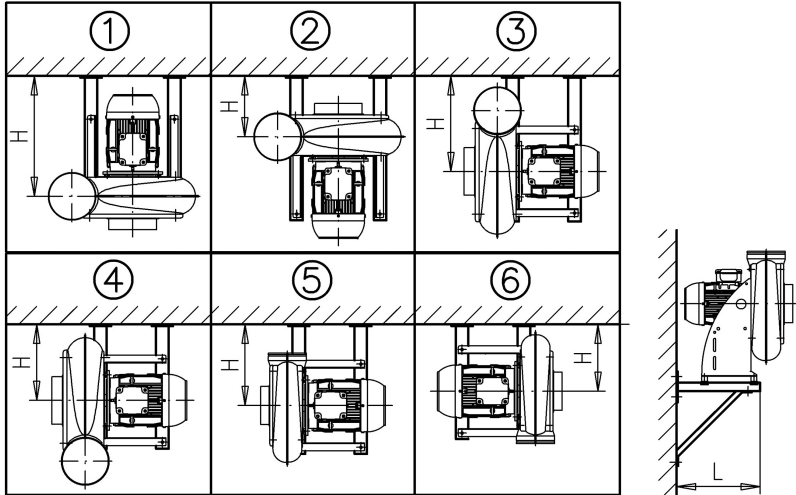

Fig. 25: Mounting position on the wall bracket

Series	[mm]	1	2	3	4	5	6
CMVpro 125	L	500	500	500	500	500	500
	H	420	180	310	270	300	290
CMVpro 160	L	500	500	500	500	500	500
	H	430	180	330	290	300	300
CMVpro 200	L	500	750	750	500	750	750
	H	490	290	470	290	440	440
CMVpro 250	L	750	750	750	750	750	750
	H	690	290	490	420	450	450
CMVpro 315	L	750	750	1000	750	1000	1000
	H	710	280	640	430	580	600
CMVpro 400	L	750	1000	1000	1000	1000	1000
	H	790	400	670	560	580	610



## 7.7 Ceiling mounting

### **⚠ DANGER** Risk of injury due to fan falling



Injuries by pinching and crushing of body parts.

- ▶ Lift and secure fan with suitable equipment when mounting.

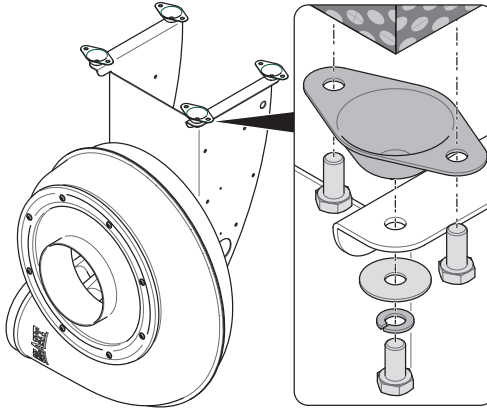

Conditions:

- Installation location requirements ⇒ Chap. 7.2 [▶ 36].
- Fastening elements and vibration absorbers present according to manufacturer's recommendation ⇒ Chap. 7.4 [▶ 38].

Fig. 26: Fastening recommendation for ceiling mounting

1. Transfer the hole pattern of the vibration absorbers onto the ceiling.



See technical data sheet for the hole pattern dimensioning of the support.

2. Install anchoring elements (anchors) according to supplier's instructions.
3. Fix vibration absorbers to anchoring elements.
4. Fasten fan to vibration absorbers tightly.

## 7.8 Connecting fan to ductwork

### **NOTICE** Risk of damage due to deformation of fan housing

Impeller touches casing or inlet cover.

- Connection tubes attached directly to fan connections transmit prohibited stresses to the fan housing, e.g. due to thermal expansion.
- ▶ Only connect fan connections to ductwork with sleeves.
- ▶ Mount sleeves properly.

### **NOTICE** Risk of damage due to lateral forces

Cracking of the sleeve.

- Sleeves can only minimally compensate for a lateral/radial duct misalignment.
- ▶ Align connection tubes precisely.
- ▶ Use supports for supplemental securing of connection tubes.



A detachable duct section (1, see image) is provided at the inlet connection for maintenance and repair work on the impeller. The length of the duct section shall correspond to at least the diameter of the inlet connection or the fan size.

Check beforehand:

- Turn the impeller by hand and check that it is smooth running.
- Check the fan and ductwork for tools left behind, mounting residues, or foreign objects.

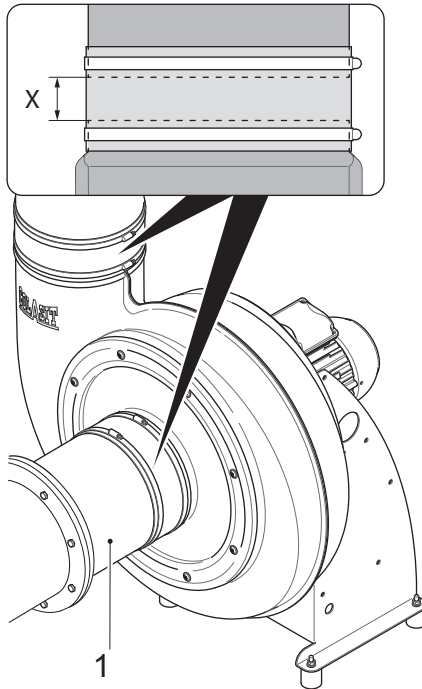

Fig. 27: Distance to ductwork connection

Procedure:

1. Push the sleeve  
⇒ Chap. 5.3.2 [► 29] over the ductwork end together with the hose clamps.
2. Mount the ductwork and adjust it to the fan connection.
3. Observe the permissible distance X (see detail view).  
**Standard:** X = 30 - 40 mm  
**Wellflex** (from conductive material): X = 100 - 110 mm (overlap ductwork end 30 mm each side)
4. Push the sleeve onto the ductwork end and fan connection equally, and secure it with hose clamps.
5. Check that the sleeve has been mounted in a flexible, stress-free manner.



As alternatives, Wellflex sleeves or sleeves with two-sided flanges  
⇒ Chap. 5.3.3 [► 29] are available (use in zone 2 environment if the piping is still in the explosion protection zone).

## 7.9 Connecting condensate drain to siphon

### **NOTICE** Environmental damage due to toxic condensate

- ▶ If possible, direct condensate downstream of the siphon back into the process.
- ▶ Collect condensate in the collecting container and dispose of according to regulations.



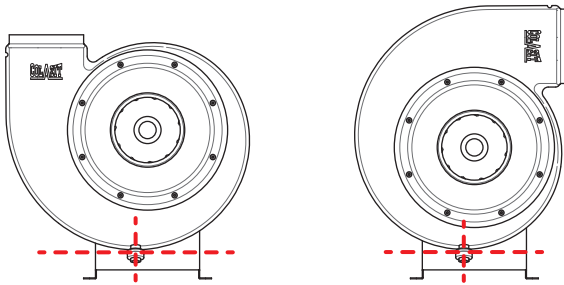

Fig. 28: Proper position of the casing drain



The casing drain shall always be located at the lowest point of the fan housing's current mounting position.

When mounting as a retrofit, an opening for the casing drain shall be cut in the splinter protection.

- Weld drain pipe (outer diameter 20 mm) to casing drain (type V)  
⇒ Chap. 5.3.5 [► 30].
- Connect drain pipe to siphon.

### 7.9.1 Siphon calculations and execution

#### Required siphon height and installation height

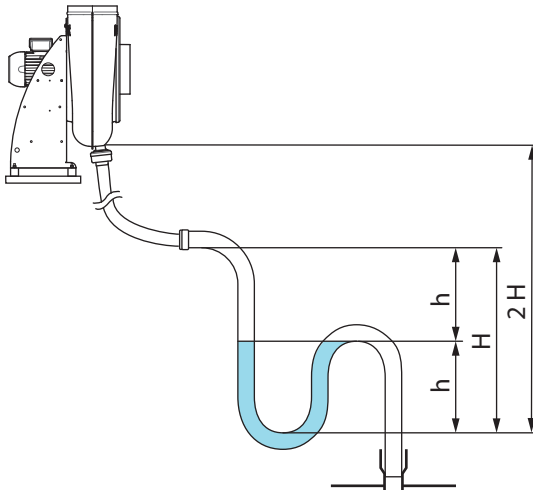

Fig. 29: Siphon height and installation height

**Calculation formula with SI units:**

$$h = \frac{p_{stat}}{10} + 15$$

$$H = 2 \cdot h = 2 \cdot \frac{p_{stat}}{10} + 30$$

**Legend:**

$h$  = min. siphon height [mm]

$p_{stat}$  = static fan pressure [Pa]

$H$  = installation height [mm]

**Siphon height [mm]:**

At least 1/10 of the maximum static fan pressure  $p_{\text{stat}}$  [Pa].

**Height difference between casing drain and siphon overflow:**

If the siphon height "h" is not observed, the condensate will not drain and will be directed to the fan.



When planning for and mounting the siphon, observe a minimum installation height of 2 x H.

**Instructions for execution of the siphon**

- For negative pressure operation of the fan: If the siphon is insufficiently dimensioned or not filled with water, there is a risk that false air will be sucked in.
- Ensure functionality of the siphon: It is imperative to fill it with water before placing in service or after an extensive downtime period.
- For outside mounting, ensure frost-resistant execution of condensate drain and siphon.
- If there are space limitations (siphon height), mount siphon in a floor opening.

## 7.10 Final inspection

- Check that all screw connections on the fan and all fastening elements of the foundation (baseplate) or mounting surface are tight.
- Inspect splinter protection ⇒ Chap. 7.3 [▶ 37].
- If present in ductwork:
  - Shut-off dampers for inlet and outlet connections are closed.
  - Service openings are shut.
- Complete ATEX test report ⇒ Chap. 15.1 [▶ 82].

## 8 Electrical installation

### 8.1 Safety instructions

These safety instructions warn against dangers that can arise during electrical installation of the fan.

#### **⚠ DANGER Risk of injury due to electrical energy**

Immediate danger to life due to respiratory and cardiac arrest.

- Erroneous or insufficient execution of the electrical connections, the wiring, and the cable routing as well as the electrical safeguards of the fan.
- ▶ Only authorized, qualified electricians may carry out the electrical installation and connect the fan to the power supply.
- ▶ The electrical installation is to be executed in accordance with the standard EN 60204-1, the technical connection requirements, and the relevant regulations.



#### **⚠ WARNING Trip and fall hazard due to cables run along the floor**

Bruises and other injuries.

- ▶ Motor connection cables run along the floor are to be run properly and protected by a cover.
- ▶ Indicate the trip hazard with floor markings.



#### **⚠ WARNING Risk of electrical shock due to electrostatic charge**

Subsequent injuries due to response upon being startled.

- As a precaution, take protective measures against electrostatic charge when operating the fan.
- ▶ Ground the fan support.
- ▶ For outside mounting, connect the fan support to the lightning protection system.



#### **⚠ CAUTION Electrical hazards due to improper layout/undersizing of the electric motor and protective devices.**

##### **Operation outside of the specified characteristic curves.**

- ▶ The application limits of the electric motor must be greater than or equal to the application limits of the fan.
- ▶ Size electrical protective devices according to the electric motor and connection cables.
- ▶ Operate only within the specified characteristic curves (flow rate and differential pressure) according to the technical data sheet.



### 8.2 Electrical protective devices

#### 8.2.1 Isolation switch installation

##### **Improper use of isolation switch**



The isolation switch is only a protective device for disconnecting the fan from electrical power during mounting, maintenance, or repair work and not to turn the fan on and off in the context of operation.

The isolation switch

- is a required protective device,
- shall be installed in an easily-accessible location near the fan,
- provides qualified personnel a means of directly controlling and disconnecting the electrical power supply from the fan,
- shall therefore be executed as a lockable all-pole disconnect switch.

**⚠ DANGER** Use only an explosion-proof isolation switch if the isolation switch is installed in a potentially explosive area.

### 8.2.2 Motor protection switch installation

An electric motor with a nominal power rating over 0.5 kW is to be protected against overload and connected to the electrical power supply with a motor protection device (overload and short circuit protection) suitable for this.

#### **NOTICE** Risk of overheating of the electric motor

Damage to motor

The motor protection switch does not reliably protect the electric motor from overheating, particularly with insufficient motor cooling due to low speed, defective fan impeller, or clogged ventilation grid.



- ▶ The installation of a motor protection switch is the responsibility of the operator.
- ▶ Specify the motor protection switch based on the motor rated current on the nameplate.



If a frequency converter (FC) is used, clarify whether integrated motor protection functions allow for fan operation without an additional motor protection switch.

The FC is to be parameterized with the motor data by qualified personnel.

### 8.2.3 PTC thermistor tripping device installation

Based on ATEX zone and FC operation, the electric motor of the fan is equipped with thermal motor protection. There are 3 PTC sensors (PTC thermistors) in the motor windings for temperature monitoring, with an additional terminal in the terminal box.

The PTC sensors are to be connected to an ATEX-certified PTC thermistor tripping device. Observe the following points when doing so:

- For the connection of the PTC thermistor tripping device, read the equipment manual and the operating instructions of the electric motor.
- Feed the connection cable into the terminal box of the electric motor through an Ex cable gland.



PTC thermistor tripping devices are usually not approved for use in potentially explosive atmospheres and must be installed in a safe location (e.g., in a protective casing or in the FC control cabinet).

#### **Connecting PTC thermistor tripping unit to FC**

When connected to a FC, shutdown should be performed by the "safe stop" safety function. This ensures that no residual voltage is applied to the motor windings and that the electric motor can cool down as quickly as possible.

### 8.2.4 Starting current limiter

**NOTICE** Strong mechanical load by the fan.  
Thermal and electrodynamic load on the motor windings.

Reduced service life of the fan.

Disturbance of nearby electrical equipment, such as controllers.



- When larger fans are switched on and ramped up under full mains voltage, a high inrush current is generated.
- When the fan is started directly, excessive torque occurs that can severely stress and damage the impeller and motor bearings.
- ▶ The manufacturer recommends the use of a starting current limiter starting with motor ratings of 3 kW (e.g. star-delta starter, soft starter, or soft start with frequency converter (FC)).

At the latest, for fans with a motor rating above 4 kW, the starting current is to be limited by one of the listed methods or equipment:

- Star-delta start-up
- Soft start/soft starter
- FC with current-limiting and start-up characteristics.



Observe the national regulations and limit values of the power system operator for direct start-up of three-phase motors.

### 8.3 Instructions for frequency converter (FC) use

**DANGER** Risk of injury due to impeller explosion

Serious injuries due to debris being launched out.



- Exceeding the maximum speed after a malfunction or faulty operating condition of the frequency converter.
- ▶ Splinter protection shall be mounted on the fan ⇒ Chap. 7.3 [▶ 37].
- ▶ The manufacturer recommends using a frequency converter with an integrated SLS safety function.
- ▶ Alternatively, implement higher-level drive control with an SLS safety sub-function.



The SLS (Safely Limited Speed) safety function prevents the electric motor from exceeding a specified speed limit.

**DANGER** Danger to life due to ignition of explosive gas mixtures by electric sparks

Death or serious injuries.



- Spark formation in electric motor.
- ▶ Check whether the explosion protection marking of the electric motor is also valid for operation with a frequency converter.
- ▶ If a frequency converter (FC) is used, the fan must be equipped with an explosion-proof electric motor (Ex db) if the FC and electric motor are not ATEX certified as a unit.
- ▶ Only install frequency converter in a safe location (control cabinet).

**⚠ WARNING Risk of injury due to high contact voltage**

Injury by electric shock.



- If long cable shields are not connected/grounded, high contact voltages can occur during operation.
- ▶ Connect cable shields of motor connection cables and signal lines to a common reference potential.
- ▶ Do not use protective earth connections for shielding purposes.

**⚠ WARNING Risk of injury due to dangerous residual voltage**

Injury by electric shock.



- After the fan has been switched off, dangerous residual voltage is still present in the frequency converter.
- ▶ The operating instructions of the frequency converter provide information about the time to be observed until this residual voltage has dropped to a safe value.
- ▶ Before beginning work on the electrical components, always establish an electrically safe work condition of the frequency converter.

### 8.3.1 Frequency converter (FC) installation options

For CMVpro 125-400 type centrifugal fans, different executions of electric motors (IM, PM, EC) can be selected as a drive:

- IM ... Standard asynchronous motor/three-phase motor
- PM ... Permanent magnet motor
- EC ... Brushless DC motor



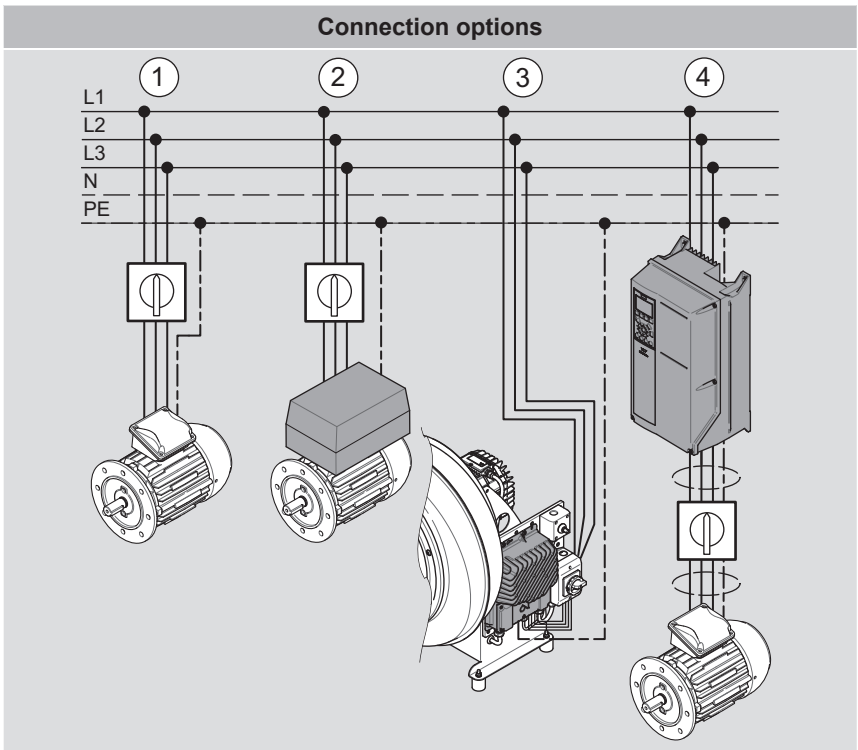

Depending on the execution, an electric motor can either be connected directly (1) to the electrical mains or can/shall be operated with a FC.

The FC is either

- directly attached to the electric motor (2, order option),
- mounted on the fan support (3, order option),
- or installed separately (4, customer solution).

**NOTICE** Risk of damaging the frequency converter



Do not manipulate the isolation switch when the electric motor is running if connection option 4 is used.

### 8.3.2 Frequency converter (FC) parameterization

#### **NOTICE** Risk of damage due to erroneous parameterization

Unpredictable fan behavior resulting in damage.

- ▶ Carry out parameterization carefully according to the FC operating instructions. The specialist shall be familiar with the FC. If necessary, consult the supplier.
- ▶ For basic setup, enter the motor data according to the nameplate on the electric motor.
- ▶ Enter the maximum frequency/speed limit according to the fan nameplate or technical data sheet. For FC operation, additional min./max. frequency limits are indicated on the motor nameplate (or additional nameplate)  
⇒ Chap. 5.2 [▶ 27].
- ▶ Enter frequency and current limit according to manufacturer specifications.
- ▶ Enter the acceleration and braking times with regard to the following table.
- ▶ Record the parameters that were entered.

To prevent mechanically overloading the fan, observe these minimum permissible acceleration and braking times:

Electric motor nominal power [kW]	Acceleration/braking time [s]
< 1.5	min. 15
> 1.5	min. 30



To avoid an FC error message, a longer acceleration/braking time could be necessary.



#### Parameterization for PM motors

Parameterization for PM motors differs significantly from three-phase motors. The FC and motor manufacturers offer support for this.

### 8.3.3 Connecting the electric motor to a frequency converter (FC)

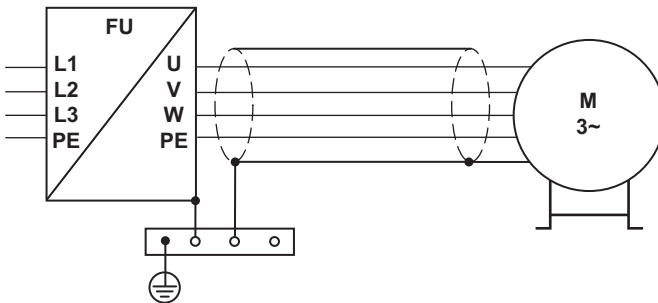

Fig. 30: Connection principle for short motor cable (FC close to fan)

## EMC-compliant connection for FC operation



Observe the EMC instructions of the fan manufacturer as well as the operating instructions of the FC manufacturer.

In particular, the maximum permissible length of the motor connection cable between the FC and the electric motor as well as the corresponding grounding concept.

1. If possible, connect the cable shield of the motor connection cable directly to the FC output with a grounding bar.
2. Install the isolation switch in the EMC execution and/or ATEX execution given in the guidelines of these operating instructions.

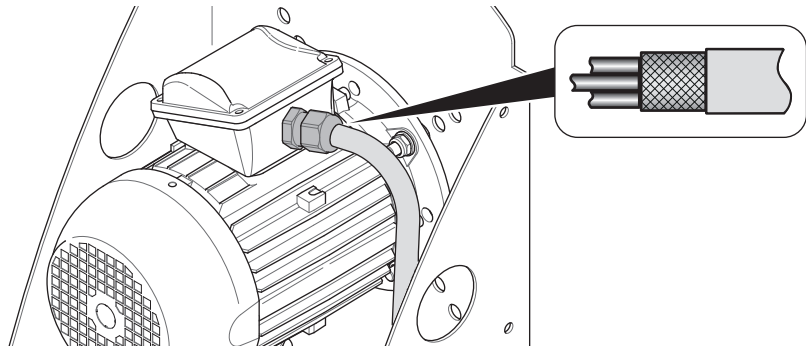

Fig. 31: EMC cable gland

3. Secure the motor connection cable to the motor terminal box with an EMC cable gland.
  - Strip the cable end appropriately so that contact can be made with the cable shield.
4. Connect the motor connection cable to the electric motor  
⇒ Chap. 8.5 [► 52].

## 8.4 Making ATEX-compliant ground connections

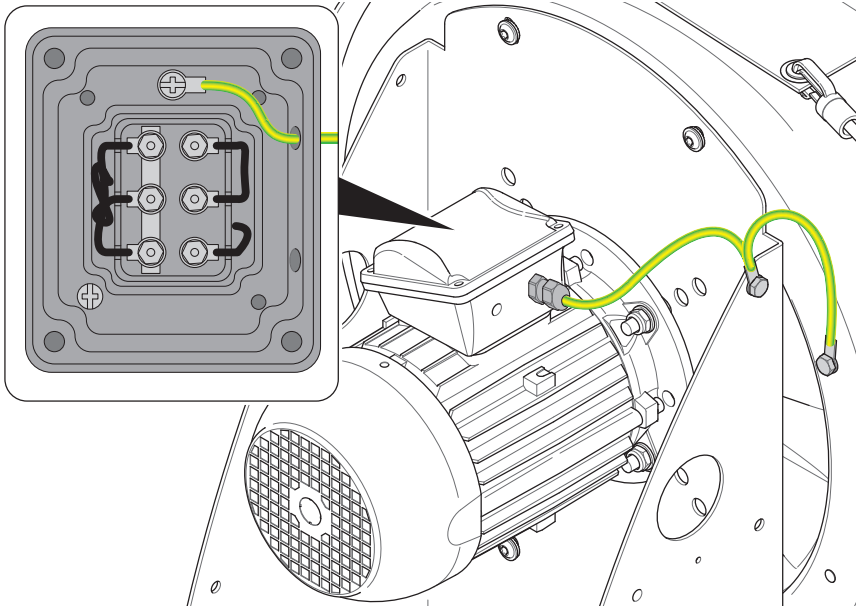

Fig. 32: Grounding cable on fan

To dissipate static charge, the housing and support of the fan are connected to the protective earthing connection in the terminal box via the grounding cable (see detailed view).

The cross section of the grounding cable must be at least 10 mm<sup>2</sup>.



These grounding connections on the fan are installed by the manufacturer or distributor before delivery.

## 8.5 Connecting the electric motor

This chapter describes the direct connection of a three-phase motor (IM) to the electrical power supply (connection option No. 1 in overview ⇒ Chap. 8.3.1 [► 48]).

For instructions on connection to a frequency converter ⇒ Chap. 8.3.3 [► 50].

### Sizing and installing the motor connection cable

Adequately size the cross section of the motor connection cable, taking into account:

- Applicable standards and regulations
- Cable lengths
- Rated current
- Environmental conditions
- Type of installation



To size the connection cable, consult the cable manufacturer's tables for current-carrying capacity or request sizing information directly from the cable manufacturer.

When running the cable, observe the following essential principles:

- Avoid damaging the cable by pinching, cutting, pulling, etc. during installation.
- Run connection cables in the building securely with clamps or mounting brackets, and protect them from damage with cable conduit.
- For protection against vibration, run the connection cable between the fan and cable fasteners to the installation location such that it is flexible and movable.

### Making the cable connection

- **⚠ DANGER** Establish an electrically safe work condition before beginning work.
- Connect the connection cable to the motor protection switch/fuses and the isolation switch.
  - Ensure correct connection of the phase conductors.
  - Seal all cable entries such that they are splash-proof.
- Compare the existing mains voltage and mains frequency with the data on the motor nameplate and determine the connection type of the electric motor (star or delta connection).

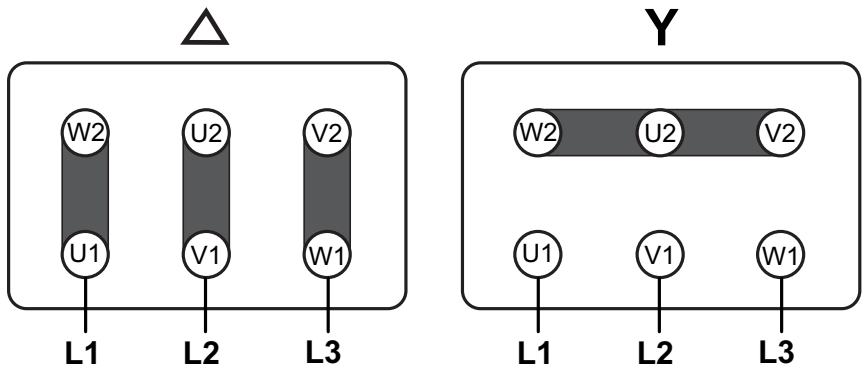

Fig. 33: Terminal assignment for delta and star connection

- Open terminal box on electric motor.
- If necessary, move the jumpers on the terminal board according to the terminal assignment.



The terminal assignment is also located on the inside of the terminal box cover.

- Connect the phase conductors (L1, L2, L3) of the motor connection cable to the terminal board in the correct order.

- Use insulated ring terminals for phase conductors.
- Attach the protective earthing (PE) to the protective earthing connection in the terminal box using a ring terminal and serrated lock washer.
- Check:
  - Only ATEX cable gland(s) and ATEX blind plugs are allowed.
  - Cable gland on the terminal box is suitable for the diameter of the connection cable.
  - All unused cable inlets on the terminal box are sealed watertight with blind plugs.
  - Sealing ring and sealing surface on the terminal box are clean.
- Close terminal box.

## 8.6 Mounting motor cover

After completion of the electrical installation work, an optional motor cover can be installed on a fan mounted outdoors ⇒ Chap. 5.3.10 [► 31].

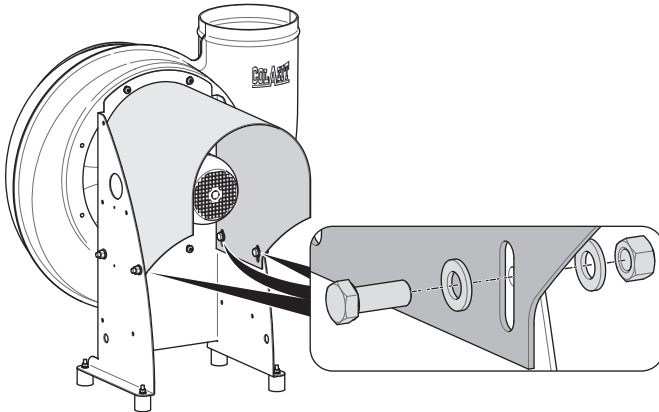

Fig. 34: Mounting motor cover

- Fasten the motor cover to the support as depicted.

## 8.7 Final inspection

- Verify mains and motor connections with motor nameplate data.
- Check the sizing and setting of the electrical protective devices (fuses, motor protection switch).
- Check installation of motor connection cable and isolation switch.
  - Three-phase mains voltage is applied to the line side of the isolation switch.
- Check connections of protective earthing (PE) and grounding for fixed position and for execution compliant with standards.
- If frequency converter (FC) is used:
  - Check FC terminal assignment, shield connection, and cable strain relief.

- Check and record important FC parameters and settings: Maximum output frequency, V/f characteristic curves, acceleration and braking times ⇒ Chap. 8.3 [▶ 47].



If required for control and placement in service, connect an external control unit to the FC.

- Complete ATEX test report ⇒ Chap. 15.1 [▶ 82].

## 9 Placement in service

### 9.1 Safety instructions

These safety instructions warn against dangers that can arise when placing the fan in service.

#### **⚠️ WARNING Risk of injury when placing the fan in service.**

Injuries due to electrical, mechanical, and chemical hazards.

- ▶ Installation work on the fan as well as final inspection have been completed in their entirety ⇒ Chap. 7 [▶ 36], ⇒ Chap. 8 [▶ 45].
- ▶ Initial and subsequent placement in service is only to be completed by authorized mounting personnel.
- ▶ Secure the isolation switch with a personal padlock to prevent unauthorized energization until all checks and preparations have been carried out. Hang tag on isolation switch.
- ▶ For free sucking or blowing out installation of the fan:  
Before energization, ensure that no one remains in the hazardous area of the inlet and/or outlet connections.
- ▶ Do not place a fan in service that is iced over. Pieces of ice can then come off and cause serious injuries and material damage. Do not remove ice from the fan forcibly or with chemical deicers.
- ▶ An electrician is responsible for energization of the fan.



### 9.2 Carrying out placement in service

Open the shut-off or damper valves of the fan's supply air duct and discharge duct.

#### 9.2.1 Check motor rotation direction

Procedure:

- Briefly turn the fan on and off with the isolation switch.
- Check motor rotation direction and compare with direction of rotation arrow on the fan housing. ⇒ Chap. 5.2 [▶ 27].



To check the direction of rotation, observe the fan impeller of the electric motor or use a motor tester for non-contact determination of the direction of rotation.

- If the direction of rotation is incorrect, have an electrician switch two phase connections of the isolation switch or in the terminal box of the electric motor, or, if available, change the direction of rotation on the frequency converter.

#### 9.2.2 Functional test of the frequency converter (FC, optional accessory)

Procedure:

- Test start/stop and acceleration behavior starting at a low frequency (25 Hz).
- Increase fan speed from minimum to maximum speed ⇒ Chap. 8.3.2 [▶ 50]
  - with an external signal from the higher-level controller,



- with FC control elements or an external control unit,
- with the local potentiometer ⇒ Chap. 5.3.8 [► 31].

Check during the functional test:

- Check acceleration and braking time ⇒ Chap. 8.3 [► 47].
- Commands shall cause corresponding speed changes.
- The electric motor may not generate any unusual vibration or noises when operating within the characteristic curve range according to the technical data sheet.
- Conduct speed measurement.
  - **NOTICE** Do not exceed the maximum speed of the impeller or the maximum frequency of the electric motor according to the technical data sheet/motor nameplate.
- During start/stop operations, the FC may not display an error message or trigger a protective function.

### 9.2.3

#### Conduct test run

##### **⚠ DANGER** Explosion hazard during test run

Death or serious injuries upon explosion.



- The fan shall never be located in an explosive atmosphere during the test run.
- ▶ Take all necessary safety precautions and measures to ensure that no explosive atmosphere exists during the test run.

Run the fan at the designated operating point, or at the operating impeller speed on the nameplate, for at least 1 hour.

##### **At the beginning of the test run:**

- Check for irregular running, unusual vibration, or noises.
- Once the operating speed has been reached, the current draw of the electric motor may not exceed the nominal value according to the motor nameplate.
- Check for leak tightness and flexible mounting of the sleeves on the fan.
- Perform vibration measurement on the fan's electric motor and compare with the table for vibration limits according to ISO 14694:

Status	Category	Permissible vibration when flexibly mounted (effective value/RMS) [mm/s]
Start-up	BV-2	9,0
	BV-3	6,3
Alarm	BV-2	14,0
	BV-3	11,8
Shutdown	BV-2	*

Status	Category	Permissible vibration when flexibly mounted (effective value/RMS) [mm/s]
	BV-3	12,5

\* Establish based on historical limit values.



The measured data provides comparison values during maintenance.

Heating, ventilation, air conditioning (HVAC), and agriculture: BV-2 < 3.7 kW  
Industrial processes, etc.: BV-3 > 3.7 kW

#### At the end of the test run:

- Compare current values and parameters with initial values and parameters from the beginning of the test run:
  - Irregular running, vibration, or noises.
  - Current draw of the electric motor.
  - Vibration measurement.
- Check leak tightness of the sleeves.
- Measure temperature of the electric motor and compare with information in the technical data sheet or on the nameplate.
- Create a test report during initial commissioning.
- The initial commissioning of the fan must also be documented with an ATEX test report ⇒ Chap. 15.1 [► 82]. Either deliver the completed ATEX test report to the operator or keep it with the project documents.

## 10 Operation

### 10.1 Safety instruction

This safety instruction warns against dangers that can arise during fan operation.

#### **⚠️ WARNING** Risk of injury due to fan operation

Injuries due to electrical, mechanical, and chemical hazards or explosions.



- ▶ Only qualified and authorized operating personnel may operate the fan and clean the outside of it.
- ▶ In the event of an operating fault, assign qualified personnel to rectify the fault.

### 10.2 Operating instructions

The fan is

- either operated with a higher-level, automatic control
- or manually switched on and off with operating elements on the plant side.



The operating personnel are also responsible for regularly checking the operating condition of the fan ⇒ Chap. 11.3.1 [▶ 61].

#### **Actions to take in the event of a malfunction**

1. Shut the fan down and inform supervisory personnel.
2. In case of emergency, immediately carry out emergency measures ⇒ Chap. 3.10 [▶ 22].
3. Shut down system components affected by fan failure.
4. Assign qualified personnel to rectify the fault ⇒ Chap. 12.2 [▶ 64].

### 10.3 Outside cleaning

#### **⚠️ WARNING** Risk of injury due to moisture penetration in current-carrying components

Injury by electric shock.



- ▶ Never clean electric motor or additional electrical components such as isolation switch, frequency converter, control cabinet, etc. with a water jet, pressure washer, or steam cleaner.

Procedure:

- Clean fan housing and plastic parts with a damp cloth.  
**⚠️ DANGER** Spark formation due to static charge - do not use a dry cloth!
- Contamination and dust deposits on the cooling fins and fan cowl of the electric motor are only to be removed by dry means or with a damp cloth.
- Keep the installation site of the fan clean.



Observe cleaning interval and adjust if necessary ⇒ Chap. 11.2 [▶ 61].

# 11 Maintenance

## 11.1 Safety instructions

These safety instructions warn against dangers that can arise when performing maintenance on the fan.

### **⚠ DANGER** Risk of injury due to maintenance work on the fan in a potentially explosive atmosphere

Death or serious injuries upon explosion.

Injuries due to electrical, mechanical, and chemical hazards.



- ▶ Control the operating condition via authorized operating personnel with appropriate ATEX training.
- ▶ All other maintenance work only to be performed by authorized maintenance personnel with appropriate ATEX training and certification.
- ▶ An electrician is responsible for energization of the fan.

### **SAFETY INSTRUCTIONS**

- ▶ Wear special personal protective equipment for use in potentially explosive atmospheres ⇒ Chap. 3.2.1 [▶ 19].
- ▶ In the access and work areas of the maintenance work
  - eliminate trip and fall hazards,
  - ensure sufficient lighting,
  - keep clean and tidy.
- ▶ Secure the isolation switch with a personal padlock to prevent unauthorized energization until completion of the maintenance work. Hang tag on isolation switch.
- ▶ In a potentially explosive atmosphere, only use tools and equipment that are non-sparking and approved for the existing explosion protection zone.
- ▶ When working inside the fan, as protection from hazardous, aggressive, and explosive conveyed media:
  - Shut the provided shut-off damper to the supply air duct and discharge duct.
  - Ensure that no conveyed medium can flow in.
  - If provided, drain condensate to the casing drain.
  - Be mindful of harmful deposits and condensate residue.
- ▶ When working inside the fan, ensure that the impeller is stationary and prevented from automatically being rotated by supply or discharge air.
- ▶ After completion of work
  - check functionality of all safeguards,
  - remove all tools and materials from the work area,
  - wipe up spilled substances and dispose of them properly.

### **⚠ DANGER** Risk of explosion due to electrostatic discharge

Death or serious injuries upon explosion.



- Cleaning of the fan housing, impeller, and plastic parts with a dry cloth leads to electrostatic charge.
- ▶ Only clean the fan with a damp cloth in a potentially explosive atmosphere.

## 11.2 Maintenance table



The maintenance intervals (W/weekly, M/monthly, 6M/semi-annually and 12M/annually) are to be adapted to the current operating conditions of the fan as determined by the customer.

Maintenance activity	Cross reference	W	M	6M	12M*
Check operating condition	⇒ Chap. 11.3.1 [► 61]	X			
Outside cleaning	⇒ Chap. 10.3 [► 59]		X		
Manual casing drain type K (option): drain condensate	⇒ Chap. 5.3.5 [► 30]	X			
Check automatic casing drain type V (option) and siphon	⇒ Chap. 5.3.5 [► 30] ⇒ Chap. 7.9.1 [► 43]	X	X		
Test run during extensive downtime	⇒ Chap. 9.2.3 [► 57]			X	
Inside inspection (if necessary)	⇒ Chap. 11.3.2 [► 62]			X	
Inside cleaning (if necessary)	⇒ Chap. 11.3.3 [► 62]			X	
Annual inspection	⇒ Chap. 11.3.4 [► 62]				X
Checking of electrical components by electrician	—				X

\* Or before placement in service after an extensive downtime period.



An hour meter is helpful.

Record all maintenance work performed in a machine logbook. A template is available from the point of contact.

## 11.3 Maintenance work



For questions regarding maintenance work and intervals, contact the distributor or manufacturer. Draw up a service contract if required.

### 11.3.1 Check operating condition

Check during fan operation:

- Visual checks:
  - For proper mounting, damage, and contamination: Safeguards (splinter protection, protective grid with free installation, optional motor cover), fan housing, electric motor, and support.
  - For leak tightness: Sleeves, inlet cover, optional hub seal.
  - For loose screw connections.
- Smooth operation of fan: For irregular running, check for vibration or noise  
⇒ Chap. 9.2.3 [► 57].

- Check electric motor, casing, and hub seal (option) for possible overheating (overload).

**⚠ CAUTION Risk of burn**

Promptly report any defects found and have them properly rectified.

### 11.3.2 Inside inspection

**NOTICE Risk of damage due to vibration**

Material damage and production downtime, reduced service life.

- Improper use or deposits on the impeller lead to imbalance and vibration.
- ▶ Switch fan off immediately in case of unusual vibration.
- ▶ Check parts in contact with the medium.



Procedure:

- Remove sleeve from the inlet connection ⇒ Chap. 7.8 [▶ 41]. If available, insert a borescope into the gap.
- Otherwise, remove the inlet cover ⇒ Chap. 12.5 [▶ 70].
- Check impeller as well as internal housing for corrosion, stress cracks, deformations, and deposits.
- If necessary, clean the impeller and inside of the casing ⇒ Chap. 11.3.3 [▶ 62].
- Replace damaged impeller immediately. Use only genuine spare parts.

### 11.3.3 Inside cleaning

**NOTICE Risk of damage due to aggressive cleaning agents and sharp cleaning tools**

Damage to plastic surfaces.

- ▶ Select cleaning agent appropriate for conveyed medium and plastic fan material.
- ▶ If possible, use warm water and a household cleaning agent.
- ▶ Use a brush or a wooden scraper to loosen deposits.



Procedure:

- If present, first open casing drain (type K) and drain condensate into a container.
- Loosen sleeve at inlet connection and remove ductwork end ⇒ Chap. 7.8 [▶ 41].
- Remove the inlet cover from the casing together with the sealing ring ⇒ Chap. 12.5 [▶ 70].
- Carefully clean impeller, inlet cover, and inside of the casing.
- **NOTICE** Do not damage the impeller blades in doing so.
- If there are heavy deposits, also clean the fan connection ducts.

### 11.3.4 Annual inspection

The mechanical and electrical functionality of the fan are assessed in the annual inspection, and its continued operation is ensured. This also applies in the event of extensive downtime.

1. Check during outside inspection

- Cracking: Fan housing, vibration absorber
  - Noise: Motor bearings
  - Proper mounting and damage of: safeguards (splinter protection, protective grid, optional motor cover), and support
  - Blockages in condensate drain (option) and missing water in siphon.
  - Damaged parts. Replace these parts immediately.
2. Test run
- Vibration measurement and condition check of the motor bearings.



Compare measured values with

- limit value according to table ⇒ Chap. 9.2.3 [► 57],
- information in the test report from initial commissioning.

- Replace motor bearings at the end of their service life or if they exhibit significant noise development due to bearing wear. To do this, remove the electric motor ⇒ Chap. 12.7 [► 73].



The motor bearings are lifetime lubricated ⇒ Chap. 2.2.3 [► 12]. For information on the bearing service life, see the operating instructions of the electric motor.

- Check hub seal (option, ⇒ Chap. 5.3.12 [► 32]) for leakage.
- Measure the current draw of the electric motor. The measured value may not exceed the rated current on the nameplate.
- Measure temperature of the electric motor and compare with information in the technical data sheet.

**⚠ CAUTION Risk of burn**

3. Inside inspection and cleaning
- Check the impeller for deformation and for damage such as cracking and corrosion.
  - If necessary, conduct outside and inside cleaning.
  - Check impeller position ⇒ Chap. 12.8 [► 74].
4. Assembly and final inspection
- Proper mounting of the splinter protection ⇒ Chap. 7.3 [► 37].
  - Fixed position of all screw connections.
  - Fixed position of all fastening elements (anchors) in the foundation (baseplate).
  - Short test run, checking for vibration and noise.

## 12 Repair

### 12.1 Safety instructions

These safety instructions warn against dangers that can arise when repairing the fan.



Modifications and adaptations to the fan are strictly prohibited and will result in the loss of ATEX certification.

#### **⚠ DANGER** Risk of injury due to repair work on the fan in a potentially explosive atmosphere

Death or serious injuries upon explosion.

Injuries due to electrical, mechanical, and chemical hazards.

- ▶ Only maintenance personnel authorized by the operator as well as service personnel authorized by the distributor or manufacturer, who have appropriate ATEX training/qualification, may carry out repair work.
- ▶ The same safety instructions as for maintenance work apply  
⇒ Chap. 11.1 [▶ 60].
- ▶ Allow the fan to cool off with the electric motor before beginning work.
- ▶ An electrician is responsible for energization of the fan.
- ▶ Explosion protection testing is to be conducted before the fan is put back in service.



### 12.2 Fault table

Identify and rectify fan faults using this table, and enter them in the machine log-book. For further information, contact customer service (see title page).

Fault	Possible cause	Fault discovery	Remedy
No function	No electrical power.	Check phase voltage.	Check electrical installation.
Conveying capacity insufficient: operating point according to technical data sheet cannot be reached.	Incorrect direction of rotation of the impeller.	Visual inspection.	Swap phases ⇒ Chap. 8.5 [▶ 52].
	Damper valve improperly positioned.	Visual inspection.	Set damper valve to proper position.
	Pressure loss in ductwork.	Measure flow rate and pressure at the operating point.	Optimize ductwork layout.
	Inflow or outflow at the fan causes high pressure loss.		Adjust the speed for the new conditions within the limits of the intended use.
Damper valve improperly positioned in ductwork.	Adjust the system.		



Fault	Possible cause	Fault discovery	Remedy
			Observe minimum distance between fan connection and damper valve or duct bend ( $L \geq 3 \times \text{duct } \emptyset$ ).
Operating speed cannot be reached.	Faulty motor winding.	Winding measurement.	Replace electric motor ⇒ Chap. 12.7 [▶ 73].
	Improper phase voltage.	Measure phase voltage.	Check/replace fuses, motor connection cable, FC cable.
	Motor overload due to improperly positioned damper valve.	Measure flow rate and pressure at the operating point.	Set damper valve to proper position.
	Motor overload due to system changes.	Fan/electric motor no longer meeting the operating point.	Consult with point of contact (see title page).
FC error message.	Improper setting of motor characteristics, start/stop ramps, acceleration/braking time.	FC display: check relevant parameters.	Set parameters properly ⇒ Chap. 8.3.2 [▶ 50].
FC error message. No acceleration from low frequency.	FC current limits are exceeded due to insufficient power factor ( $\cos \varphi$ ).	FC current limits too low?	Adjust FC parameter "Motor characteristic" (torque quadratic to speed) ⇒ Chap. 8.3 [▶ 47].
	Improper motor and/or FC size.	Motor and/or FC too small?	Design FC according to motor ⇒ Chap. 8.3 [▶ 47].
	Start ramp too steep or acceleration time too short.	Check FC parameters.	Adjust start ramp. Increase acceleration time.
Motor protection switch, PTC thermistor tripping device, or FC switches off.	Improper setting.	Measure current draw.	Set motor protection switch properly ⇒ Chap. 8.2.2 [▶ 46].
		Check FC parameters.	Parameterize FC properly.
	Faulty motor connection.	Measure current draw.	Check motor connection (star/delta) ⇒ Chap. 8.5 [▶ 52].

Fault	Possible cause	Fault discovery	Remedy	
	Overheating due to excessive current consumption.	Operating point adjusted. Defect in motor or cable.	Set operating point according to specification.	
	Impeller stiff or stopped.	Visual inspection.	Remove deposits or foreign objects ⇒ Chap. 11.3.3 [▶ 62].	
	Winding damage on the electric motor.	Winding measurement.	Repair or replace electric motor ⇒ Chap. 12.7 [▶ 73].	
	Electric motor bearing damage.	Turn electric motor by hand.	Check EMC guidelines.	
	Damaged cable, faulty cable connection.	Measurement, visual inspection.	Replace cable.	
Strong vibration.	Deposits on impeller, imbalance.	Visual inspection, vibration measurement.	Clean impeller ⇒ Chap. 11.3.3 [▶ 62].	
			Balance impeller ⇒ Chap. 5.1 [▶ 26].	
	Damaged or malformed impeller due to (prohibited) conveyed medium.	Visual inspection.	Adjust cleaning interval.	
			Replace impeller ⇒ Chap. 12.5 [▶ 70].	
			Points to observe: ⇒ Chap. 2.2.1 [▶ 9] and ⇒ Chap. 2.2.2 [▶ 12].	Clarify composition of conveyed medium and plastic resistance.
			Measure temperature of the conveyed medium.	Adjust operating conditions to intended use ⇒ Chap. 2.2.1 [▶ 9].
			Check operating point.	
			Check environmental conditions.	
			Ductwork connected directly to fan casing.	Change in length of ductwork due to thermal expansion.
Loose impeller.	Impeller loosened on motor shaft?	Check and tighten hub adapter ⇒ Chap. 12.5 [▶ 70].		

Fault	Possible cause	Fault discovery	Remedy
	Impeller dips into condensate at bottom of casing.	Type K: visual inspection.	Drain condensate ⇒ Chap. 5.3.5 [▶ 30].
		Type V: visual inspection.	Clean and replace condensate drain/siphon ⇒ Chap. 5.3.5 [▶ 30].
		-	Retrofit with casing drain.
	Loose/defective vibration absorbers or fastening elements.	Visual inspection	Tightly screw/replace vibration absorbers ⇒ Chap. 7.4 [▶ 38] and following.
	Improper mounting.	Installation location requirements met ⇒ Chap. 7.2 [▶ 36].	Fortify foundation (baseplate). Resize fastening elements (anchors).
Overheating of electric motor.	Bearing or winding damage.	Auditory inspection, current draw measurement, winding measurement.	Repair or replace electric motor ⇒ Chap. 12.7 [▶ 73].
	Impeller stiff or stopped.	Visual inspection.	Remove deposits or foreign objects ⇒ Chap. 11.3.3 [▶ 62].
	Motor overload due to improperly positioned damper valve.	Measure flow rate and pressure at the operating point.	Set damper valve to proper position.
	Motor overload due to system changes.	Fan/electric motor no longer meeting the operating point.	Consult with point of contact (see title page).
	FC does not reach required voltage.	Check FC.	Use a suitable FC.
Prohibited operating conditions.	Ductwork not leak tight.	Check for leakage.	Seal up.
	Loose hose clamps or damaged sleeves.		Re-tighten hose clamps or replace sleeves ⇒ Chap. 7.8 [▶ 41].

Fault	Possible cause	Fault discovery	Remedy
	FC parameter "max. frequency" set improperly (speed too high, overheating of electric motor).	Check FC parameters ⇒ Chap. 8.3.2 [▶ 50].	Adjust parameters according to characteristic map in technical data sheet.
Grinding noise coming from the impeller.	Casing too tight.	Check distance and alignment of ductwork to fan connection.	Adjust ductwork distance and connection (sleeves) appropriately.
	Ductwork connected to fan without sleeves.		Connect ductwork to fan with sleeves ⇒ Chap. 7.8 [▶ 41].
	Loose impeller.	Impeller loosened on motor shaft?	Check and tighten hub adapter ⇒ Chap. 12.5 [▶ 70].
	Deposits or foreign objects between impeller and inlet cover.	Determine grinding point. Check with feeler gauge.	Remove deposits or foreign objects ⇒ Chap. 11.3.3 [▶ 62].
	Impeller defect.	Visual inspection.	Replace impeller ⇒ Chap. 12.5 [▶ 70].
Audible sound from bearings.	Bearing damage.	Auditory inspection.	Replace motor bearings or exchange motor ⇒ Chap. 12.7 [▶ 73].
	End of service life reached.		Interference suppression measures with FC operation; see FC manufacturer's guidance. Check EMC guidelines.  Use current-insulated roller bearings or ceramic hybrid bearings.
	Bearing damage due to electrical discharge machining (bearing currents).	Measure voltage between the motor shaft and casing of the electric motor.	
Excessive leakage at impeller hub.	Overpressure operation of the fan (without optional hub seal).	Pressure measurement.	Operate fan at negative pressure.  Install optional hub seal.
	Hub seal worn or defective.		Visual inspection.

## 12.3 Spare parts and wear parts



### **⚠ DANGER Risk of injury due to impeller explosion**

Serious injuries due to debris being launched out.

- Prohibited spare parts.
- ▶ Only use an original impeller from the manufacturer as a spare part.



### **⚠ DANGER Risk of explosion due to prohibited spare parts**

Death or serious injuries upon explosion.

- ▶ Only use original spare parts for fan repair.
- ▶ If the fan is made of conductive plastic, the spare part must be made of the same material (PPs-el).



### **NOTICE Risk of damage due to prohibited spare parts**

Component and material damage as well as production downtime.

- Loss of ATEX certification and void of warranty.
- ▶ Only use original spare parts from the manufacturer for maintenance activities and repairs.

Order spare parts and wear parts from customer service (see title page) in a timely manner with the following information:

- Type classification of fan according to nameplate or technical data sheet.
- Desired quantity.
- Specific designation
  - of the spare part or wear part ⇒ Chap. 5.1 [▶ 26],
  - or of the option or accessory ⇒ Chap. 5.3 [▶ 28].

Have spare parts and wear parts for the impeller or hub seal available:

Pc.	Designation	Spare part	Wear part
1	Impeller	X	
1	Hub cap	X	
1	Hub adapter	X	
1	Sealing ring (inlet cover)	X	
1	Hub seal (option)		X

## 12.4 Preparation for repairs

Prepare the fan for repairs (impeller, electric motor, hub seal, etc.) as follows:

1. Observe safety instructions ⇒ Chap. 11.1 [▶ 60].
2. Switch off the fan and FC (option) and use the isolation switch to remove voltage on all phases.
3. Secure the isolation switch with a personal padlock to prevent unauthorized energization until completion of the repair work. Hang tag on isolation switch.
4. Shut the shut-off damper to the supply air duct and discharge duct.
5. Drain condensate to condensate drain type K (option).

6. Only for removal of the casing: Remove or disconnect the drain pipe to the siphon from the condensate drain type V (option).
7. Loosen sleeves on inlet and outlet connections.
8. Remove removable duct section from inlet connection ⇒ Chap. 7.8 [► 41].



### Risk of contamination of the ductwork

Cover open ductwork ends with plastic sheeting during repairs.

## 12.5 Impeller exchange

Conditions:

- Fan has been prepared for repairs ⇒ Chap. 12.4 [► 69].

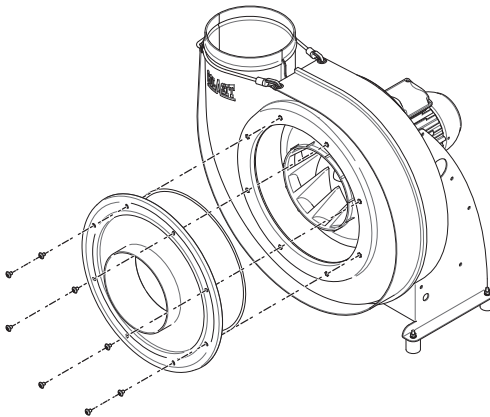

Fig. 35: Removing inlet cover

Procedure:

- Remove splinter protection.
  - Remove snap hooks.
- Loosen fastening screws on inlet cover.
- Carefully remove inlet cover from casing.
 

**NOTICE** The sealing ring can stick to the casing and become damaged.
- Remove sealing ring.

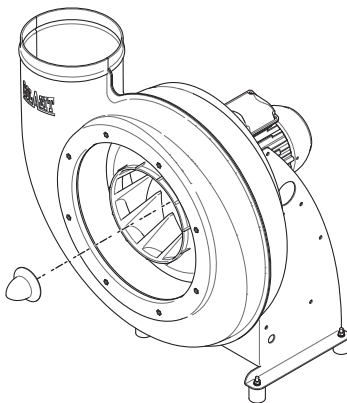

Fig. 36: Removing hub cap

- Cut out and remove hub cap with appropriate tools.
  - The hub cap cannot be removed non-destructively - order spare part in a timely manner.

**NOTICE** Do not reuse hub cap that has been removed! Only a leakproof, undamaged hub cap prevents aggressive conveyed media from corroding the motor shaft and impeller hub, resulting in destruction of the impeller.

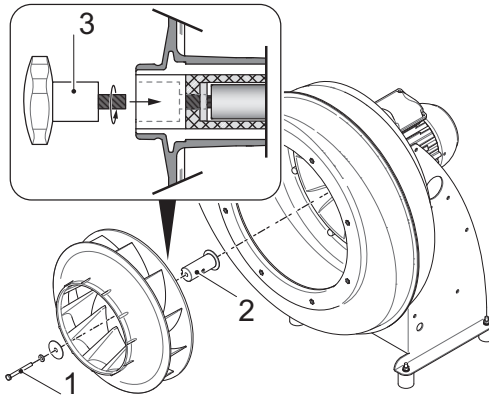

Fig. 37: Removing impeller

- Loosen impeller.
  - Loosen and remove fastening screw (1).
  - Pull hub adapter (2) from the motor shaft with a suitable release bolt (3) (see detail).
- Pull impeller and hub adapter off motor shaft.



The impeller is mounted directly to the motor shaft on fans CMVpro 125-200 with electric motors of size 100 or 112 as well as for CMVpro 250-400 with electric motors of size 132.

### Mounting instructions

- Clean and lightly grease motor shaft and impeller hub before mounting.
- Insert hub adapter with inserted key into the impeller from the outside.
- Push the impeller onto the motor shaft as far as it will go. The impeller position cannot be adjusted.

**NOTICE** Danger of bearing damage! Never strike the motor shaft when mounting the impeller.

- Tighten hub adapter with fastening screws, with RIPP LOCK® for fastener security, according to the following table.

Fan/size	Fastener threads	Max. tightening torque [Nm]
CMVpro 125	M4	6
CMVpro 160	M5	8
CMVpro 200	M6	15
CMVpro 250	M8	20
CMVpro 315	M10	20
CMVpro 400	M12	25

- Check impeller mobility.

**NOTICE** The impeller may not grind.

- Heat new hub cap evenly to approx. 60 °C with hot air blower and press onto hub. Check mounted hub cap for cracks and damage.

- Inspect sealing ring of the inlet cover for damage prior to installation and replace if necessary.
- Tighten the fastening screws of the inlet cover according to the table:

Fan/size	Fastener threads	Max. tightening torque [Nm]
CMVpro 125	M6	2
CMVpro 160 - 400	M8	5

- Conduct a test run after repair ⇒ Chap. 9.2.3 [► 57].

## 12.6 Casing exchange

Conditions:

- Fan has been prepared for repairs ⇒ Chap. 12.4 [► 69].
- Impeller has been removed ⇒ Chap. 12.5 [► 70].

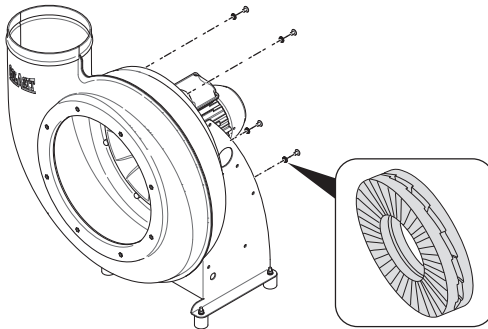

Procedure:

- Disconnect grounding cable from casing ⇒ Chap. 8.4 [► 52].
- Loosen and remove fastening screws and corresponding wedge-lock washers (Nord-Lock, see detail) from the back of the support.
- Remove casing from support.

Fig. 38: Removing casing

### Mounting instructions

- Reinstall hub seal (option) ⇒ Chap. 12.9 [► 76].
- Align casing opening to the center of the motor shaft.
- **NOTICE** Secure the fastening screws of the casing
  - with wedge-lock washers (mandatory; Nord-Lock, see detail). Do not use threadlocker (Loctite)!
  - to the tightening torque specified in the following table.

Fan/size	Fastener threads	Max. tightening torque [Nm]
CMVpro 125	M6	2
CMVpro 160 - 400	M8	5

- Tighten the grounding cable to the ground connection of the casing ⇒ Chap. 8.4 [► 52].



## 12.7 Electric motor exchange



The electric motor may only be repaired at the motor manufacturer's facility or in special workshops with an ATEX certificate of competence.

Keep the repair certificate as associated documentation.

Conditions:

- Fan has been prepared for repairs ⇒ Chap. 12.4 [► 69].
- Impeller has been removed ⇒ Chap. 12.5 [► 70].

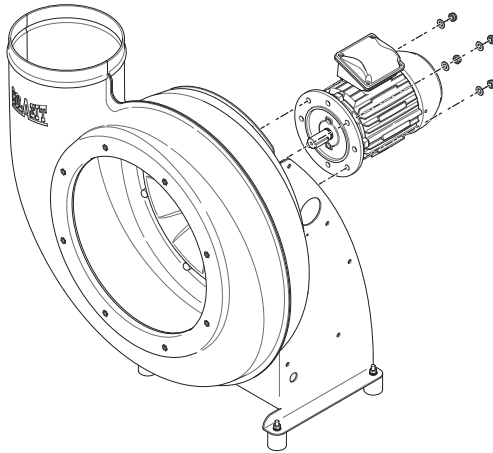

Procedure:

- Remove all cables from the terminal box of the electric motor and protect from damage.
- Support and secure the electric motor with suitable supports.
- Loosen mounting nuts on motor flange.
- Move a heavy electric motor with suitable hoisting gear.
  - Use the lifting eye bolt on the electric motor for this purpose.

Fig. 39: Removing the electric motor

### Mounting instructions

#### **NOTICE** Risk of damage to the electric motor

Damaged motor bearings.



- ▶ Protect the motor shaft/bearings from being hit during transport and mounting of the electric motor.
- ▶ Observe the instructions in the manual from the motor manufacturer.
  - Fasten mounting nuts according to the following table.
    - The thread is based on the motor size.

Thread	Max. tightening torque [Nm]
M8	22
M10	45
M12	80
M16	190

- Feed the grounding cable through a suitable Ex cable gland and connect it in the terminal box ⇒ Chap. 8.4 [► 52].
- Connect electric motor ⇒ Chap. 8.5 [► 52], ⇒ Chap. 8.2.3 [► 46].
- Check motor rotation direction ⇒ Chap. 9.2.1 [► 56].
- Mount impeller ⇒ Chap. 12.5 [► 70].
- Conduct test run ⇒ Chap. 9.2.3 [► 57].

## 12.8 Check impeller

### **⚠ DANGER** Risk of explosion due to grinding impeller

Death or serious injuries upon explosion.



- Overheating of possible grinding points.
- ▶ Be mindful of grinding noises during fan operation.
- ▶ In the event of grinding noises, switch the fan off immediately and arrange for repair.

### **NOTICE** Risk of damage due to grinding impeller

Damage to impeller.



- ▶ Perform measurement checks of distance X of the impeller according to the table.
- ▶ If necessary, tighten the fastening screw of the hub adapter.
- ▶ Determine grinding point. Remove deposits or foreign objects present in the casing ⇒ Chap. 11.3.3 [► 62].

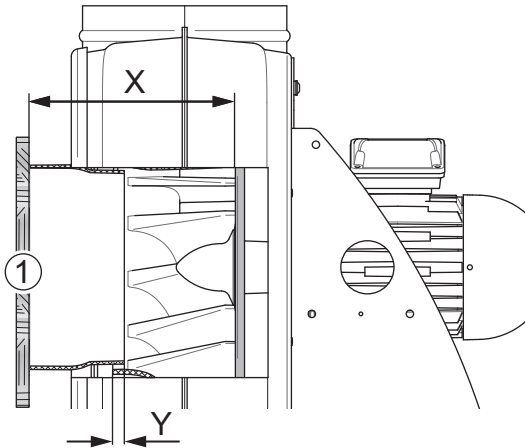

Fig. 40: Measuring impeller position (sectional view)

The overlap Y of the inlet cover taper and the impeller cannot be measured directly. Instead, the distance X from the inlet connection to the impeller support disc is measured according to the table below.



As an aid, place a wooden board (1, see illustration) across the inlet connection.

Fan/size	Distance X [mm]	Overlap Y [mm]
CMVpro 125	134	6
CMVpro 160	172	7
CMVpro 200	219	8
CMVpro 250	250	10
CMVpro 315	321	12
CMVpro 400	411	15

Procedure:

1. Prepare fan for measurement:
  - Loosen sleeve at the inlet connection.
  - Remove ductwork end at the inlet connection.
  - Check fixed position of impeller on motor shaft.
  - Check impeller mobility.
2. Conduct measurement according to figure 40.
3. Compare measured distance X with value from table.

Actions for significant deviation of measured value:

1. Remove hub cap.
2. Check hub adapter, key, and impeller hub for damage.
3. Tighten hub adapter to specified tightening torque.
4. Check impeller mobility.
5. Press new hub cap onto hub.
6. Assemble fan.
7. Conduct test run ⇒ Chap. 9.2.3 [► 57].



For necessary removal and mounting work, see ⇒ Chap. 12.5 [► 70] for mounting instructions.

## 12.9 Hub seal (option) felt ring replacement

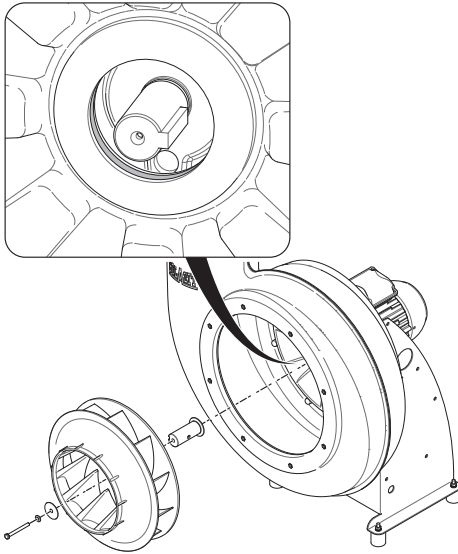

Fig. 41: Inserting hub seal

### Conditions:

- Impeller has been removed  
⇒ Chap. 12.5 [▶ 70].
- Housing is mounted and is centered with the motor shaft.

### Procedure:

1. Remove felt ring with tweezers (see detail).
2. Saturate the new felt ring soak with lubricant.  
Lubricant: Interflon Lube TF (aerosol)
3. Mount felt ring.  
**NOTICE** The felt ring may not protrude into the housing.
4. Mount the hub adapter and impeller on the motor shaft.



### Important

The impeller should turn freely by hand after mounting.

5. Allow the felt ring to run for one minute at a maximum of 1500 min<sup>-1</sup>.

### **NOTICE** Risk of damage to the fan

Smoke and chips can develop for a short time while running.

- ▶ If this happens, remove the impeller and clean the hub.

6. Assemble the fan ⇒ Chap. 12.5 [▶ 70] – see mounting instructions.

7. Conduct test run (min. 1 h) ⇒ Chap. 9.2.3 [▶ 57]. **DANGER** Conduct test run outside the Ex-zone!



## 13 Removal from service, disposal, and recycling

### 13.1 Safety instructions

These safety instructions warn against dangers that can arise during removal from service and disposal of the fan.

**⚠️ WARNING Risk of injury during removal from service and disposal of the fan**

Death or serious injuries upon explosion.

Injuries due to electrical, mechanical, and chemical hazards.

- ▶ An electrician is responsible for removal of the power supply from all phases.
- ▶ Ensure that the work area does not have a potentially explosive atmosphere.
- ▶ Removal of the fan to be completed only by authorized mounting personnel.
- ▶ Removal for disposal is to be completed only by authorized transport personnel.



### 13.2 Environmental protection

**📌 NOTICE Environmental hazards upon disposal of the fan**

Water and soil pollution

- Check the fan for conveyed medium deposits that are harmful to health and the environment.
- ▶ Dispose of contaminated components such as casing and impeller as special waste.



Housing and impeller can be made of different plastics.



For proper recycling, an abbreviation of the plastic type is indicated on the impeller, inlet cover, and casing.

### 13.3 Removal from service

**⚠️ WARNING Risk of injury due to improper removal**

Injuries by pinching and crushing of body parts.

- ▶ Wear protective equipment.
- ▶ Safeguard work area and prevent unauthorized access using enclosures, safety nets, etc.
- ▶ Secure a fan that is mounted on the wall or ceiling against falling or tipping over by attaching suitable supports.
- ▶ Provide suitable transport aids for transportation of the fan.



**⚠️ WARNING Risk of injury due to escape or inflow of a conveyed medium with the ability to cause adverse health effects**

Risk of eye irritation, cough, difficulty breathing, burn, and suffocation.

- ▶ Wear protective equipment.
- ▶ Close shut-off damper to inlet and outlet connections.
- ▶ Watch for deposits and condensate of the conveyed medium in the fan and ductwork.



**Procedure:**

- Switch off fan and FC (option) and prepare them for removal:
  - Allow to cool down.
  - Close shut-off dampers in supply air and discharge air ductwork.
  - Drain and dispose of condensate in the condensate drain (option).
- To be completed by electrician:
  - Switch off higher-level control and FC.
  - Secure isolation switch with a personal padlock to prevent unauthorized energization and hang tag.
  - Remove power to the fan and additional electrical components on all phases, and disconnect the electrical connection.
- Remove piping and ductwork connections:
  - Disconnect the drain pipe to the siphon from casing drain type V (option).
  - Remove sleeves on inlet and outlet connections.
- Loosen threaded fasteners for the vibration absorbers on the support.
- Prepare fan for disposal in a location suitable for this purpose.

## 13.4 Disposal instructions

When disposing of the fan, observe all nationally applicable regulations and legal requirements for waste disposal, and comply with regional environmental protection regulations.

Preferably, commission a waste disposal company for proper recycling or disposal.

**Disassembly instructions**

- Separate the fan components into material groups and dispose of them separately:
  - Metals
  - Plastics
  - Electrical components



Dispose of plastic parts contaminated by conveyed media that are harmful to health and the environment as special waste.

## 14

## EU - Declaration of conformity

We, the manufacturer

COLASIT AG  
 Faulenbachweg 63  
 3700 Spiez  
 Switzerland

declare under our sole responsibility  
 that the product of the series CMVpro  
 125-400 ATEX

Plastic industrial fan  
 CMVpro 125 ATEX  
 CMVpro 160 ATEX  
 CMVpro 200 ATEX  
 CMVpro 250 ATEX  
 CMVpro 315 ATEX  
 CMVpro 400 ATEX

to which this declaration refers is in conformity with the provisions of the following EU directives and harmonized standards as of the date of issue stated:

EU Directives	Machinery Directive 2006/42/EC
	EMC Directive 2014/30/EU
	ATEX Directive 2014/34/EU
Harmonized standards	
EN ISO 12100: 2011	EN ISO 12499: 2008
EN 60204-1: 2019	EN IEC 61000-6-4:2019
EN 1127-1: 2019	EN ISO 80079-36: 2016
EN ISO 80079-37: 2016	EN 14986: 2017
EN 60079-0: 2018	EN 60079-1: 2014
EN 60079-7: 2015	EN 60079-15: 2019
Name and address of the document manager	Andreas Roth COLASIT AG , Faulenbachweg 63 3700 Spiez, Switzerland
Deposit of the assessment and technical documentation with	Eurofins Electric + Electronic Testing AG, Fehraltdorf (1258) Deposit no. 19CH-0129.X01

Spiez, 6/7/2021



U. Moser (Division manager)

## 15 ATEX - Declaration of Conformity

- (2) Equipment, components, and protective systems intended for use in potentially explosive atmospheres – **Directive 2014/34/EU (ATEX)**.

(3)	Declaration of Conformity number	TD-000 824
(4)	Equipment group	Non-electrical equipment and components of equipment group II, categories 2 and 3
	Product description	Plastic industrial fan
	Product designations	CMVpro 125 ATEX, CMVpro 160 ATEX, CMVpro 200 ATEX, CMVpro 250 ATEX, CMVpro 315 ATEX, CMVpro 400 ATEX
(5)	Manufacturer	COLASIT AG
(6)	Address	Faulenbachweg 63 3700 Spiez Switzerland

- (7) The design of this equipment and the various executions are specified in the appendix to this Declaration of Conformity and in the technical report.
- (8) Colasit AG certifies compliance with the essential health and safety requirements for the design and construction of equipment and protective systems intended for use in potentially explosive atmospheres according to Annex II of Directive 2014/34/EU.

The results of the test are recorded in the confidential test report TD-000 823 and deposited with the notified body (Eurofins, Fehraltdorf, 1258) under the number 19CH-0129.X01.









- (9) The essential health and safety requirements are met through conformance with:

EN ISO 80079-36: 2016	EN ISO 80079-37: 2016
EN 1127-1: 2019	EN 14986: 2017
EN 60079-0:2018	EN 60079-1:2014
EN 60079-7:2015	EN 60079-15:2019

- (10) If there is an X after the certificate number, special conditions for safe use of the equipment are referred to in the appendix of this certificate.
- (11) This Declaration of Conformity relates only to the design and construction of the specified equipment group according to Directive 2014/34/EU. Further requirements of this Directive apply to the manufacture of this equipment and its placement on the market.



(12) The identification of the equipment group shall contain the following information:

Conveyed medium Zone 2, Installation site no Zone		II 3/-G	Ex h IIB+H2 T3 or T4* Gc/-
Conveyed medium Zone 2, Installation site Zone 2		II 3G	Ex h IIB+H2 T3 or T4* Gc
Conveyed medium no Zone, Installation site Zone 2		II -/3G	Ex h IIB+H2 T3 or T4* -/Gc
Conveyed medium Zone 1, Installation site no Zone		II 2/-G	Ex h IIB+H2 T3 or T4* Gb/-
Conveyed medium Zone 2, Installation site Zone 1		II 3/2G	Ex h IIB+H2 T3 or T4* Gc/Gb
Conveyed medium Zone 1, Installation site Zone 1		II 2G	Ex h IIB+H2 T3 or T4* Gb
Conveyed medium Zone 1, Installation site Zone 2		II 2/3G	Ex h IIB+H2 T3 or T4* Gb/Gc
Conveyed medium no Zone, Installation site Zone 1		II -/2G	Ex h IIB+H2 T3 or T4* -/Gb

\*) T3 or T4 according to the attached motor. The fan as a non-electrical component corresponds to T4.

COLASIT AG

Spiez, 11/25/2022



U. Moser  
(Division manager)



Andreas Roth  
(Authorized Representative)

(13) **Appendix of the ATEX Declaration of Conformity**

(14) Declaration of Conformity TD-000 824

(15) **Description of the product**

- Centrifugal fans of the series CMVpro 125 to 400 ATEX are used to extract room air or process exhaust air. They are driven directly by electric motors.
- Conveyed media are chemically aggressive gases, vapors, or air contaminated with them.
- Material selection depends on the requirements (zone inside/outside) and the presence of droplets.

(16) Test report TD-000 823

### (17) Special conditions

- If the fans are used in potentially explosive atmospheres of Zone 1 or 2, they may only be operated with electric motors for which a corresponding approval (EU type examination certificate) is available.
- Ambient temperature:  $T_{amb.}$  -20 °C to +40 °C
- Maximum temperature of the conveyed medium: according to data sheet, max. 60 °C.
- The minimum volume flow rate through the fan, which is listed on the data sheet, must be observed.
- The fan must be connected to the local potential equalization.
- The operator is responsible for ensuring that only substances are conveyed to which the materials used are resistant.
- Modifications to the named products are not permitted unless expressly authorized in writing by the manufacturer.
- All service and repair work shall be carried out by trained maintenance personnel.

#### Additional information

- Centrifugal fans of equipment category 3 may only be used for the extraction of gases for which the frequency of occurrence of flammable or explosive atmospheres corresponds ATEX Zone 2.
- If the named products are incorporated into a higher-level machine, the new risks arising from the incorporation must be assessed by the manufacturer of the new machine.



This certificate may only be reproduced in full and without modification.

## 15.1 ATEX test report

The ATEX test report:

- Serves to verify the proper mounting and initial commissioning as well as the permissible operating conditions of an ATEX-certified fan.
- For ongoing operation, it is recommended to keep a machine logbook in which the explosion protection testing is also entered.



Templates for the ATEX test report and machine logbook can be obtained from the point of contact.

# Index

<b>A</b>	
Anchoring elements	39, 40, 41
Annual inspection	61, 62
Application limits	12
ATEX	9, 12, 13, 24, 44, 46, 55, 58, 60, 64, 80, 82
Attachment points	33
<b>B</b>	
Backward curved	26
Balanced	26
Balancing quality	26
Bearing damage	20, 34, 66
Bearing service life	63
Bracing angle	40
<b>C</b>	
Cable strain relief	54
Casing drain	13, 30, 43, 60, 61, 62, 67
Ceiling mounting	28, 36, 38, 41
Center of gravity	33
Centrifugal fan	7, 26, 48
Chain sling	35
Claims for damages	34
Collecting container	42
Complaint	33
Complaint period	34
Complaints	34
Condensate drain	30, 43, 44, 63, 67, 69, 78
Condensation	34
Connection thread	38
Connection tube	26
Cracking	41, 63
Crane hook	34
<b>D</b>	
Damper valve	56, 64, 65, 67
Danger to life	17, 20, 33, 45
Degree of protection	32
Direction of rotation arrow	56
Disposable packing	34
Disposal	7, 15, 77, 78
Disposal instructions	34, 78
Drain pipe	43
Duct misalignment	41
Duct section	42, 70
Ductwork	10, 11, 13, 22, 29, 41, 44, 64, 66, 68, 70
Ductwork end	42, 62, 75
<b>E</b>	
EC motor	48
Electrician	16, 20, 45, 56, 60, 61, 64, 77, 78
Electromagnetic fields	20
Entry protection	32
Environmental damage	42
Explosion protection	12, 64
Explosion protection marking	10, 12, 25
Eyelets	37
<b>F</b>	
False air	44
Fan cowl	21, 37, 59
Fan housing	21, 23, 29, 41, 56, 59, 61, 63
Fan impeller	56
Fan size	42
Fan support	39
Fastening elements	36, 39, 41, 44, 63, 67
FC parameterization	30, 31
Felt ring	32, 76
Fire extinguishers	20, 23
Flange connections	29
Floor load	36
Floor mounting	39
Floor opening	44
Forklift	35
Forks	35
Foundation (baseplate)	36, 39, 44, 63, 67
Free sucking	22, 32, 56
Frost-resistant	44
<b>H</b>	
Health protection	14
Hoisting gear	33, 34, 73

Hole pattern	39, 41
Hose clamps	29, 42, 67
Hub adapter	26, 66, 68, 71
Hub cap	26, 70, 71, 75
Hub seal	11, 14, 32, 61, 63, 68, 69, 72
Humidity	34

## I

IM motor	48
Impeller blades	26
Impeller breakage	26
Impeller position	63
Incoming goods inspection	33
Inflow	13, 22, 36, 60, 77
Inlet connection	13, 26, 42, 62, 70, 74, 75
Inlet cover	26, 70, 77
Inside cleaning	61, 62, 63
Installation height	43, 44
Installation location	14, 15, 34, 36, 39, 41, 53, 67
Installation position	38
Installation site	59
Installation sites	36
Intermediate storage	34
Isolation switch	8, 19, 23, 30, 45, 51, 53, 54, 56, 59, 60, 69, 78

## L

Lateral forces	41
Leakage current	20
Lifting eye bolt	33, 34, 35, 73
Load	33
Load capacity	36, 38
Load handling attachments	34

## M

Mains voltage	47, 53, 54
Maintenance	14, 15, 16, 58, 60
Maintenance intervals	14, 61
Maintenance opening	26
Maintenance personnel	16, 60, 64
Maintenance switch	30
Maintenance work	12, 38, 60, 61, 64
Material damage	7, 9, 12, 17, 33, 36, 38, 56, 62, 69
Minimum distance	21, 37, 65

Misuse	12
Motor	11, 38
Motor axis	26
Motor bearings	13, 47, 63, 73
Motor cover	31, 36, 54, 61, 63
Motor nameplate	53, 54, 57
Motor rotation direction	56
Motor shaft	26, 66, 68, 71, 73
Mounting personnel	15, 16, 56
Mounting position	40, 43
Mounting residues	42
Mounting surface	36, 44

## N

Nameplate	10, 11, 46, 50, 63, 69
Negative pressure operation	44
Nominal speed	31

## O

OFF position	30
Operating conditions	10, 12, 61, 66
Operating faults	20, 28, 59
Operating personnel	16, 59, 60
Operating temperature	10, 12
Operator	7, 9, 10, 13, 14, 15, 18, 23, 46, 64
Original packaging	34
Outlet connection	11, 13, 26, 27, 29, 32, 36, 44, 56, 70, 77
Outside cleaning	16, 61
Overheating	62
Overload	46
Overpressure	13, 32

## P

Package	33, 34, 35
Packing	34
Padlock	19, 20, 30, 56, 60, 69, 78
Pallet stacker	35
Personal padlock	19, 20, 56, 60, 69, 78
Piping	78
PM motor	48, 50
Potentiometer	31, 57
Production downtime	36, 38, 62, 69
Protective devices	54, 60
Protective earthing	54

Protective equipment	13, 15, 18, 19, 22, 33, 36, 60, 77
Protective grid	12, 22, 32, 61, 63
PVC	23

## R

Regulations	14, 33, 45, 78
Repair work	16, 19, 20, 30, 37, 42, 45, 64, 69
Return shipment	34
Rubber band	37

## S

Safeguards	15, 22
Safety instructions	33, 60, 64, 69
Safety protection	32
Screw connections	39, 44, 61, 63
Sealing ring	26, 54, 62, 70
Service openings	36, 44
Shipping documents	33
Shore hardness	38
Short circuit	20
Shut-off damper	22, 36, 44, 60, 69, 77
Signs	27
Siphon	13, 30, 42, 43, 61, 63, 67, 70, 78
Siphon height	43, 44
Siphon overflow	44
Sleeve	13, 26, 41, 62, 75
Sling	33, 34, 35
Smooth running	42
Snap hooks	37, 70
Spare parts	12, 69
Specification sheet	8, 9, 10
Speed adjustment	31
Speed control	30
Splinter protection	12, 22, 26, 37, 43, 44, 61, 63, 70
Start-up	19, 21
Storage temperature	34
Supplier's instructions	39, 40, 41
Supply air duct	56, 60, 69
Support	21, 26, 35, 36, 39, 45, 49, 54, 61, 63, 72, 77, 78
Support braces	40
Supports	41
Swinging movements	33

## T

Terminal	13
Terms and conditions	34
Test report	58, 63
Test run	57, 61, 63, 72, 74, 75
Total weight	38
Toxic condensate	42
Transport aids	33
Transport damage	33, 34
Transport paperwork	33
Transport personnel	15, 77
Transport protection	33
Transport route	33

## V

Vibration	12, 26, 28, 38, 53, 57, 58, 61, 62, 66
Vibration absorbers	28, 41
Vibration resistant	36

## W

Wall bracket	28, 31, 36, 39, 40
Wall mounting	28, 31, 38, 39
Warning symbols	17
Wear part	32, 69
Welding edge	37
Wellflex sleeves	42
Work area	22, 36, 37, 60, 77







# Innovative technology for the sake of the environment

- since 1945 -

When it comes to thermoplastics, Colasit AG is one of the world's leading brands in fan and system engineering. Our qualified staff impress with technical expertise and great dedication, guaranteeing you the highest quality on all five continents.

We set our targets high to see all our projects through to success and complete every job to your complete satisfaction. We combine tradition and innovation – our many years of experience are a foundational component of our work, just as is the incorporation of the latest technology.

Place your trust in us – we accompany you throughout all phases of your project, starting from planning with the manufacturer all the way down to commissioning.

