

Operating instructions

CMVeco 125-400

Centrifugal fan with V-belt drive

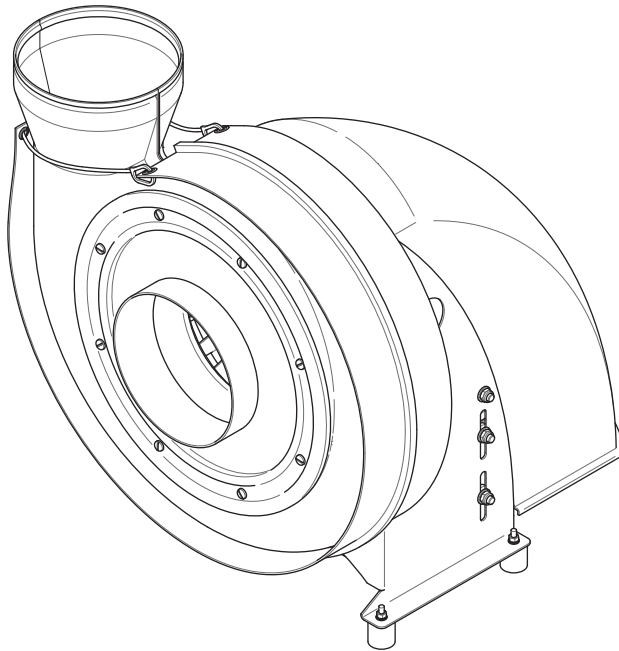

Your point of contact:

Revision history table

Version		Description	Date	Name
1-en	EU	First version published.	10/02/2023	A. Roth

Document identification

Translation of the original German operating instructions.
Colasit TD-000851

Contact information

Manufacturer

COLASIT AG
Faulenbachweg 63
CH-3700 Spiez
E-mail: fans@colasit.com
Website: www.colasit.com
Phone: +41 (0)33 655 61 61

Table of contents

1	Operating instruction information	7
1.1	Further applicable documents	8
1.2	Copyright	8
2	Additional safety instructions	9
2.1	Use and storage of the operating instructions	9
2.2	Intended application of the fan	9
2.2.1	Intended use	9
2.2.2	Reasonably foreseeable misuse	11
2.2.3	Equipment limits	12
2.2.4	Residual risks	12
2.3	Target groups and personnel requirements	13
2.3.1	Operator	13
2.3.2	Transport personnel	14
2.3.3	Mounting personnel	14
2.3.4	Operating personnel	15
2.3.5	Maintenance personnel	15
3	Essential safety instructions	16
3.1	Notation of safety instructions	16
3.2	Personal protective equipment	17
3.3	Mechanical hazards	18
3.4	Electrical hazards	18
3.4.1	Danger due to electromagnetic interferences	19
3.5	Thermal hazards	19
3.6	Noise hazard	20
3.7	Conveyed medium hazards	20
3.8	Dangers due to insufficient safety	20
3.9	Actions to take in an emergency	20
4	Structure and function	22
4.1	Overview	22
4.1.1	Execution with V-belt drive	22
4.2	Signs and warning symbols on the fan with V-belt drive	23
4.3	Options and accessories	24
4.3.1	Vibration absorbers	24
4.3.2	Sleeves	24
4.3.3	Sleeves with flange	25
4.3.4	Flange connections	25
4.3.5	Condensate drain	25
4.3.6	Isolation switch	26

4.3.7	Frequency converter (FC).....	26
4.3.8	Speed adjustment potentiometer.....	26
4.3.9	Wall bracket.....	27
4.3.10	Protective grid.....	27
4.3.11	V-ring hub seal.....	27
4.3.12	Hub seal felt ring.....	28
4.3.13	Impeller back-plates.....	28
5	Transport.....	29
5.1	Safety instructions.....	29
5.2	Incoming goods inspection.....	29
5.3	Packing.....	30
5.4	Intermediate storage.....	30
5.5	Transport to installation location.....	30
5.5.1	Transport by crane.....	30
5.5.2	Transport by pallet stacker or forklift.....	31
6	Mechanical installation.....	32
6.1	Safety instructions.....	32
6.2	Installation location requirements (only for BD).....	32
6.3	V-belt drive – check proper mounting.....	33
6.4	Splinter protection - check proper mounting.....	34
6.5	Mounting the vibration absorbers (only for BD).....	35
6.6	Floor mounting.....	35
6.7	Wall mounting (only for BD).....	36
6.8	Connecting fan to ductwork.....	37
6.9	Connecting condensate drain to siphon.....	39
6.9.1	Siphon calculations and execution.....	39
6.10	Final inspection.....	40
7	Electrical installation.....	41
7.1	Safety instructions.....	41
7.2	Electrical protective devices.....	41
7.2.1	Isolation switch installation.....	41
7.2.2	Motor protection switch installation.....	42
7.2.3	Starting current limiter.....	42
7.3	Instructions for frequency converter (FC) use.....	43
7.3.1	Frequency converter (FC) installation options.....	43
7.3.2	Frequency converter (FC) parameterization.....	45
7.3.3	Connecting the electric motor to a frequency converter (FC).....	45
7.4	Connecting the electric motor.....	46
7.5	Mounting the hood on the V-belt drive (only for BD).....	48
7.6	Final inspection.....	48

8	Placement in service	50
8.1	Safety instructions	50
8.2	Carrying out placement in service	50
8.2.1	Check motor rotation direction	50
8.2.2	Functional test of the frequency converter (FC, optional accessory).....	50
8.2.3	Conduct test run.....	51
9	Operation	53
9.1	Safety instruction	53
9.2	Operating instructions	53
9.3	Outside cleaning.....	53
10	Maintenance	54
10.1	Safety instructions	54
10.2	Maintenance table	54
10.3	Maintenance work	55
10.3.1	Check operating condition	55
10.3.2	Inside inspection	56
10.3.3	Inside cleaning	56
10.3.4	Annual inspection.....	56
11	Repair	58
11.1	Safety instructions	58
11.2	Fault table.....	58
11.3	Spare parts and wear parts	63
11.4	Preparation for repairs.....	64
11.5	Impeller exchange	64
11.6	Casing exchange.....	66
11.7	Electric motor exchange.....	67
11.8	Measuring and setting impeller position	69
11.9	Replacing the V-ring seal (option).....	71
11.10	Hub seal (option) felt ring replacement	72
11.11	Replacing the drive belt.....	73
11.12	Measuring and setting belt tension.....	74
12	Removal from service, disposal, and recycling	75
12.1	Safety instructions	75
12.2	Environmental protection.....	75
12.3	Removal from service.....	75
12.4	Disposal instructions	76
13	EU - Declaration of conformity	77



Index	78
--------------------	-----------

1 Operating instruction information

Scope

These operating instructions provide qualified personnel with all essential safety instructions, information, and guidance for working with CMVeco 125-400 type centrifugal fans.

All phases of a centrifugal fan from transport, mounting, and placement in service to repairs and disposal are covered.

Careful reading of and compliance with these operating instructions will help to avoid injuries as well as environmental and material damage, ensure operational safety and reliability of the centrifugal fan, and minimize downtime.

Storage location

The operating instructions and associated documents are to be stored near the centrifugal fan such that they are easily accessible to qualified personnel at all times.



The operating instructions and associated documents are also to be provided in electronic form upon delivery of the fan. This gives the operator the ability to print new operating instructions in the event that they go missing or to replace illegible or missing pages.

Design notes

For the sake of simplification, in these operating instructions,

- the company Colasit AG is referred to as the “manufacturer,”
- the CMVeco 125/125 centrifugal fan is referred to as the CMVeco 125, for example,
- all sizes (CMVeco 125-400) are generally referred to as the “fan,”
- “frequency converter” is abbreviated as “FC,”
- the drive type “V-belt drive” is abbreviated as “BD” for “belt drive,”
- chapter and page number references appear as follows: ⇨ Chap. 1 [▶ 7]

The images in these operating instructions are for illustrative purposes and could differ from the actual execution.

In the interest of our customers, we reserve the right to make changes as a result of technical developments.

Translation note

The German language version of this document is the original set of operating instructions.

Inquiries

If possible, clarify any ambiguities in a given language version with the aid of the original operating instructions. Ambiguities regarding the operating instructions are to immediately be clarified with the manufacturer. Placement in service of or other work on the fan is only permitted after successful clarification.

1.1 Further applicable documents

In addition to these operating instructions, the following documents and guidance shall be available as associated documents for working on the fan:

- Technical data sheet for the fan with complete technical data, including application limitations.
- Order confirmation or the specification sheet for the conveyed medium with information on the (limited) resistance of the fan to certain chemical substances. See also “Permissible conveyed media” ⇒ Chap. 2.2.1 [► 9].



The order confirmation also provides details regarding the full scope of delivery.

- Operating instructions for the electric motor.
- Operating instructions for devices or equipment that were installed or included (e.g. FC or isolation switch).

Additional document

- Fan guideline FC/grounding/EMC/motors (EMC Guide) of the manufacturer, if the fan is intended for operation with a frequency converter (FC).

1.2 Copyright

These operating instructions are protected by copyright.

© COLASIT AG. All rights reserved.

The use and distribution of the operating instructions is permitted in the context of using the fan. Any other use is only permitted with the written consent of the manufacturer.

2 Additional safety instructions

This chapter contains information relevant to safety and additional as well as more in-depth safety instructions for operators and technical specialists.



Additional safety instructions

Depending on the execution of the fan, associated documents can contain additional operating instructions with important safety instructions.

2.1 Use and storage of the operating instructions

- Before beginning mounting procedures or working on the fan, read these operating instructions carefully and completely.
- After use, always return the operating instructions to the marked storage location near the fan.

2.2 Intended application of the fan

The fan is intended for conveying gaseous media and is designed and manufactured in accordance with the state of the art and the recognized technical safety regulations.

Nevertheless, the fan may pose a danger to life and limb of personnel or third parties as well as material damage. Special care is therefore to be taken to ensure that the fan is in technically sound condition and that it is used as intended.

2.2.1 Intended use

The fan is intended exclusively for industrial and commercial use and for installation in a complete system. The fan may only be transported, mounted, operated, maintained, and repaired by trained technical specialists

⇒ Chap. 2.3 [▶ 13].

Permissible conveyed media

In general, conveyance of dust-free air is permissible within the parameters specified in the technical data sheet.

Conveyance of corrosive, hazardous, gaseous media is restricted as follows:

1. The following apply to a conveyed medium that is specified in the fan's technical data sheet:
 - The fan is suitable exclusively for conveyance of the specified medium.
 - The service life of the fan could be limited if there is a corresponding note in the order confirmation or the specification sheet.
2. The following apply to a conveyed medium that is specified as "undefined" in the fan's technical data sheet:
 - The fan is suitable for conveyance of those corrosive, hazardous media to which the plastics of the fan and sleeves are resistant.
 - For independent assessment, the operator is to consult the pertinent available resistance lists for plastics. The SIMCHEM guide is found on the manufacturer's website (www.colasit.com).



The impeller, inlet cover, and casing of the fan are marked with an abbreviation for material identification.

- The order confirmation or the additional specification sheet contains further information and notes regarding a potential reduction in service life of the fan.
3. The following apply if, according to the operator's information, the conveyed medium contains several chemical substances:
 - The named importer or the manufacturer confirms the resistance of the fan to these chemical substances in the order confirmation or the specification sheet, which is an associated document.
 - The service life of the fan can be limited if there is a corresponding note in the order confirmation or the specification sheet.

Permissible environmental conditions

1. The permissible operating and ambient temperature ranges are indicated on the fan nameplate.
The minimum permissible operating temperature for the plastic parts of the fan is -20 °C.
2. The following applies if this information is missing from the nameplate:
 - Permissible ambient temperature range of the electric motor: See nameplate of the electric motor or the operating instructions/declaration of conformity of the motor manufacturer.
3. At operating temperatures below 4 °C, it is to be ensured by means of a constant minimum flow rate that
 - no condensate freezes in the fan or ductwork.
 - no pieces of ice from the ductwork get into the fan.

Procedure for process changes

- The operator is to ensure upon a process change that
 - the fan can withstand the parameters changed or the new conveyed medium,
 - the operating conditions according to the technical data sheet and nameplate plate are adhered to.

Operating conditions

- The permissible operating conditions of the fan are defined by the parameters and limit values on the technical data sheet or on the nameplate.

Note especially:

- The drive motor of the fan is designed for continuous operation (S1) or FC operation (S9).
- Maximum speed, which is dependent on
 - the temperature of the conveyed medium,
 - chemicals present and their concentration in the air stream.
- Prevention of excessive self-heating:

- The operating point (see characteristic map on the technical data sheet) shall be above the minimum permissible conveyed volume.
- So that no or minimal conveyed medium escapes from the impeller hub,
 - operate the fan at a negative pressure,
 - or use a hub seal.



The leakage value of the supplied fan can be requested from the distributor.

- The fan must be equipped with vibration absorbers ⇒ Chap. 6.5 [► 35].
- Observe the permissible vibration limits according to standard values.
- The fan may not be mechanically stressed at the inlet and outlet connections.
 - Decouple the ductwork from the fan via the sleeves ⇒ Chap. 6.8 [► 37].
- When using a frequency converter,
 - observe limit values for the acceleration time and braking time ⇒ Chap. 7.3 [► 43],
 - the electrical connection to the motor is to be EMC compliant, with cable shield and grounding ⇒ Chap. 7.3.3 [► 45].
- Series or parallel operation of fans is permitted only after clarification and approval by the manufacturer or importer named in the operating instructions.

Intended use also includes compliance with all safety regulations and guidelines in these operating instructions.

2.2.2 Reasonably foreseeable misuse

Any use of the fan other than that for which it is intended or any other use is considered misuse and can lead to dangerous situations. The manufacturer assumes no responsibility for resulting injuries or material damage.

The following list of misuse is exemplary and not exhaustive.

- Operation of the fan in potentially explosive environments or with a flammable, explosive conveyed medium.
- Operation of the fan outside the parameters and limit values specified in the technical data sheet.
- Operation of the fan with prohibited conveyed media, such as solids and dust.
- Operation of the fan in spite of strong vibration or with disturbances that create an objectionable condition in terms of safety.
- Prohibited configurations of the frequency converter.
- Removal of components or tampering with components that ensure safe and proper function of the fan (e.g. vibration absorbers, splinter protection, sleeves, protective grid).
- Improperly conducted maintenance work.

- Use of non-original spare parts.
- Unauthorized modifications or alterations to the fan without the written consent of the manufacturer.
- Any use of the fan that does not comply with the essential safety regulations of these operating instructions.
 - Operation without operating instructions and associated documents.
 - Operation with illegible or missing warning signs.

2.2.3 Equipment limits

Spatial dimensions

The dimensions of the fan are specified in the technical data sheet.

Application limits

The operating temperature range and further operating conditions are specified in the technical data sheet and on the nameplate.

Interfaces

The fan has the following interfaces:

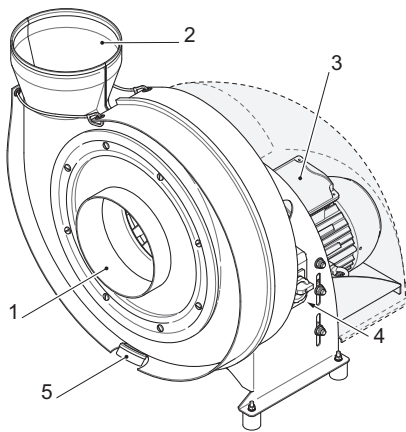

1. Inlet connection (suction side): Connection to supply air ductwork with sleeve.
2. Outlet connection (pressure side): Connection to discharge air ductwork with sleeve.
3. Terminal box on electric motor.
4. Isolation switch: Terminal for electrical supply for accessories and options (e.g. FC for electric motor).
5. Casing drain (option) for manual draining or connection to siphon.

Fig. 1: Interfaces on fan

Service life

The fan is designed for an expected service life of 15 years.

The motor bearings of quality motors are designed for a service life of 40,000 hours when used as intended.

The environmental, application, and operating conditions determine the service life of the hub seal (wear parts) of a given application.

2.2.4 Residual risks

The fan is designed and manufactured in accordance with the state of the art and the recognized technical safety regulations. Residual risks nevertheless remain. They are indicated by safety instructions in these operating instructions and require the user to proceed with caution.

Hazardous, aggressive conveyed media

Residue and deposits of the conveyed medium can reside in the fan or flow in from the ductwork.

- Qualified personnel responsible for maintenance and repair work shall
 - be trained in handling hazardous conveyed media,
 - wear suitable personal protective equipment,
 - coordinate with the operator when taking suitable protective and lock-out measures.

When operating the fan in an overpressure condition, the conveyed medium can escape at the impeller hub and lead to adverse health effects.

- When used with hazardous conveyed media, the fan is to be operated at a negative pressure or outfitted with the optional hub seal
⇒ Chap. 4.3.12 [► 28].

2.3 Target groups and personnel requirements

These operating instructions are intended for:

- The operator of the system in which the fan is installed.
- The qualified personnel who carry out work on the fan during its various life cycle phases, from installation to disposal.

The duties and personnel requirements for these target groups are described next.

2.3.1 Operator

The operator is the person who operates the fan for commercial or economic purposes or who allows a third party to use it and who assumes legal liability during its operation.

The operator has the following duties:

- Comply with the minimum safety and health protection regulations for the use of work equipment and performance of activities on the fan.
- Keep current on national and local occupational safety and health regulations.
- Prepare Safety Data Sheets when the conveyed medium contains hazardous substances.
- Identify via risk assessment all additional dangers that arise due to special working conditions at the fan installation location.
 - Based on the risk assessment, derive, define, and implement for qualified personnel the appropriate protective measures and operating instructions for safe maintenance and other activities.
 - Adapt these operating instructions to current applicable standards and regulations at the time of operation.
- Ensure that the fan is always in a technically sound condition under observance of the maintenance intervals per these operating instructions.
- Initiate and verify that the function and integrity of all fan safeguards are checked regularly.

- Ensure that all manufacturer's regulations are observed upon retrofitting of safeguards.
- Determine the priority of shutting down the fan upon system malfunction or in an emergency.
- Clearly determine and regulate the responsibility for installation, servicing, maintenance, and repair of the fan.
- Ensure that the responsible qualified personnel
 - have read and understood these operating instructions,
 - have adequate occupational qualifications,
 - are regularly trained in the dangers related to and measures to take upon malfunction or in an emergency.
- Store these operating instructions and associated documents in their entirety in legible condition in an identified location near the fan.
- Save and protect the electronic version of these operating instructions.
- Prepare the required protective equipment and direct the wearing of this protective equipment by qualified personnel based on the operating and environmental conditions.

2.3.2 Transport personnel

The transport personnel are responsible for the transport of the fan to the installation location and for its removal for disposal at the end of its lifespan.

The transport personnel:

- Possess all necessary occupational knowledge, qualifications, and authorizations for operating the necessary lifting and transport devices.
- Are trained in the proper application of lifting and load handling attachments.
- Are knowledgeable of the safety and accident prevention guidelines and directives as well as recognized regulations of the technology applicable to transport.
- Are authorized by the operator to perform transport operations.

2.3.3 Mounting personnel

Mounting personnel are responsible for the installation of the fan in the system and for the subsequent placement in service. Removal of the fan for disposal also falls in this area of responsibility.

- Mounting personnel consist exclusively of qualified technical specialists who possess the necessary occupational experience, knowledge, and qualifications for mechanical and electrical work on the fan.
- The technical specialist is dependable when it comes to current safety and accident prevention guidelines, directives, and recognized regulations of the technology in their line of activity, and they are instructed by the operator.
- All work on the fan's electrical components may only be carried out by electricians.
- The fan may only be connected to the frequency converter by an electrician
 - after its operating instructions have been read and understood,

- including detailed knowledge of the respective frequency converter,
- and specialized knowledge of EMC-compliant wiring (consult the manufacturer's EMC guideline).
- The fan manufacturer's declaration of conformity is invalidated upon erroneous connection of the frequency converter and electric motor.

2.3.4 Operating personnel

The fan is generally used in automatic operations with a controller.

If operating personnel are necessary, the operator ⇒ Chap. 2.3.1 [▶ 13] of the system is to determine the required education and qualifications for

- operating and outside cleaning of the fan ⇒ Chap. 9 [▶ 53].
- checking the operating condition of the fan ⇒ Chap. 10.3 [▶ 55].

2.3.5 Maintenance personnel

Maintenance personnel are responsible for the inspection, cleaning, maintenance, and repair of the fan.

- The same requirements apply as for the mounting personnel ⇒ Chap. 2.3.3 [▶ 14].
- An electrician is responsible for carrying out maintenance and repair work and for switching off and safely disconnecting the power supply from the fan.

3 Essential safety instructions

The associated documents can contain additional operating instructions with important safety instructions ⇒ Chap. 1.1 [▶ 8].

3.1 Notation of safety instructions

The safety instructions and warnings in these operating instructions are identified by the following warning symbols, signal words, and colors (electronic version of the operating instructions only), which convey the severity of the dangers.

Death or serious injuries

DANGER Danger to life due to... !



Outcome of the danger upon noncompliance...

- Conditions for prevention of the danger...
- ▶ Measures for prevention of the danger...

This safety instruction, the highest danger level, denotes a direct and immediate dangerous situation. This indicates a hazardous situation which, if not avoided, will result in death or serious injury.

Serious injuries

WARNING Risk of injury due to... !



Outcome of the danger upon noncompliance...

- Conditions for prevention of the danger...
- ▶ Measures for prevention of the danger...

A safety instruction of this danger level denotes a possible dangerous situation. This indicates a hazardous situation which, if not avoided, could result in death or serious injury with lasting effects.

Minor injuries

CAUTION Bodily injuries due to... !



Outcome of the danger upon noncompliance...

- Conditions for prevention of the danger...
- ▶ Measures for prevention of the danger...

A safety instruction of this danger level denotes a possible dangerous situation. This indicates a hazardous situation which, if not avoided, may result in minor or moderate injury, possibly with lasting effects.

Material damage

NOTICE Material damage due to... !



Outcome of the danger upon noncompliance...

- Conditions for prevention of the danger...
- ▶ Measures for prevention of the danger...

This warning instruction informs of a dangerous situation that can damage the fan or or lead to other material damage.

3.2 Personal protective equipment

The personal protective equipment to be worn:

- is to be determined and made available by the operator based on the operating conditions and conveyed medium.
- is the personal responsibility of the qualified personnel to be worn as suitable for the work to be conducted and to be supplemented as necessary.

The manufacturer recommends personal protective equipment according to the following table:

Symbol	Meaning
	Class 2 fluorescent warning vest with reflective stripes for improved visibility during transport operations.
	Close-fitting industrial safety clothing with low tear resistance for protection against introduction into rotating machinery.
	Hardhat to protect the head from falling objects, swinging loads, and strikes from sharp, pointed machine parts.
	Safety glasses to protect the eyes from airborne particles, parts, and fluids. Protection from aggressive, hazardous conveyed media or residues.
	Hearing protection required at or above noise exposure levels of 85 dB(A) or 137 dB (CPeak).
	Suitable breathing protection when in contact with aggressive, toxic conveyed media or residues.
	Work gloves for protection from injuries, burns, or contact with aggressive, toxic residues of the conveyed medium.
	Safety shoes for protection from crushing and from falling parts as well as slips and falls on slick surfaces.

3.3 Mechanical hazards

⚠ DANGER Risk of injury due to

- rotating impeller,
- rotating belt (for execution with BD),
- parts ejected with high force following impeller breakage,
- sharp corners or edges.

Serious injuries due to debris being launched out.

Crush, cut, strike, eye, or other injuries.

- Operation in a manner other than that intended (e.g. regarding temperature, speed, conveyed medium).
- ▶ Only authorized qualified personnel may conduct work on the fan.
- ▶ Prior to beginning mounting, maintenance, and repair work: Use the isolation switch to remove voltage on all phases.
- ▶ Prevent unauthorized start-up of the fan: Hang personal padlock and tag on isolation switch.
- ▶ Wear personal protective equipment.
- ▶ Do not leave any tools or mounting accessories in the fan.
- ▶ Comply with all current accident prevention guidelines.



⚠ WARNING Risk of injury due to automatic start-up

Entry and crushing of appendages.

- The fan is to be operated in a system and controlled by automatic controls.
- ▶ Prior to beginning mounting, maintenance, and repair work: Use the isolation switch to remove voltage on all phases.
- ▶ Prevent automatic start-up of the fan: Hang personal padlock and tag on isolation switch.



3.4 Electrical hazards

⚠ DANGER Danger to life due to electric shock from contact with current-carrying conductors or components under hazardous voltage.

Immediate danger to life due to respiratory and cardiac arrest.

- Only a qualified and authorized electrician may work on the power mains and the electrical components of the fan.
- ▶ Prior to beginning mounting, maintenance, and repair work: Use the isolation switch to remove voltage on all phases.
- ▶ Prevent unauthorized start-up of the fan: Hang personal padlock and tag on isolation switch.
- ▶ Establish an electrically safe work condition before beginning work.
- ▶ Promptly rectify any defects discovered in the electrical components and wiring of the fan.
- ▶ Eliminate moisture from current-carrying components to avoid a short circuit.



⚠ WARNING Risk of injury due to fire caused by short circuit

Burns, respiratory tract damage due to toxic fire smoke.

- ▶ Protect cables from mechanical, chemical, and thermal stresses.
- ▶ Regularly inspect the fan's electrical components. Replace damaged components and cables immediately.
- ▶ Have and periodically inspect suitable fire extinguishers. Observe the safety instructions on the fire extinguisher.



3.4.1

Danger due to electromagnetic interferences

Observe the following safety and hazard instructions if the fan is used with a frequency converter.

Frequency converters generate electromagnetic interference during operation and can cause high-frequency leakage current in the electric motor, supply power network, and grounding system.

⚠ CAUTION Interference from electromagnetic fields

Disturbance of sensitive electronic equipment by electromagnetic fields.

- ▶ When the fan is running, persons with pacemakers and other implanted electronic devices must not remain in the immediate vicinity of the frequency converter and electric motor.

**NOTICE Disturbances to other devices from electromagnetic fields as well as bearing damage to electric motor due to leakage current**

Exceeding legally permissible emission limits.

Reduced lifespan of the motor bearing.

Possible system operating faults and production interruptions.

- ▶ Use of suitable interference suppression and shielding methods, such as a mains suppression filter and shielded motor connection cable.
- ▶ EMC-compliant equipment design, especially for cable routing and shielding connections. See EMC Guide of the manufacturer and/or third-party equipment manufacturer.
- ▶ Observe FC manufacturer's recommendations for avoiding electromagnetic interferences.



3.5

Thermal hazards**⚠ CAUTION Risk of burn due to contact with hot surfaces**

Burns to unprotected body parts.

- The fan housing and support can reach temperatures over 60 °C due to a hot conveyed medium.
- The fan's electric motor can reach temperatures over 60 °C on its surface during operation.
- ▶ Allow a hot fan or electric motor to cool off.
- ▶ Wear protective gloves when working on the fan or electric motor.
- ▶ When mounting the fan, observe the minimum distance between the hood of the V-belt drive and neighboring components or walls
 - ⇒ Chap. 6.2 [▶ 32].



3.6 Noise hazard

⚠ CAUTION High noise level with start-up and operation of the fan

Response upon being startled as well as hearing damage and hearing loss as long-term consequences.



- ▶ Observe the information in the technical data sheet on noise emissions from ducts and the casing.
- ▶ Wear hearing protection in the vicinity of the fan when required.
- ▶ Comply with legally mandated noise control regulations. If the fan is installed outdoors, comply with environmental noise emission limit values.

3.7 Conveyed medium hazards

⚠ WARNING Risk of injury due to escape or inflow of a conveyed medium with the ability to cause adverse health effects

Risk of eye irritation, cough, difficulty breathing, burn, and suffocation.



- ▶ Clarify what medium is being conveyed.
- ▶ Observe the Safety Data Sheet(s) of the conveyed medium.
- ▶ Wear suitable personal protective equipment.
- ▶ Close the shut-off damper in the ductwork.
- ▶ Ventilate closed rooms.
- ▶ Take special safety precautions when working in confined spaces:
 - Request permit.
 - Inform supervisory personnel.
 - Assign an attendant.
 - Measure gas content in the work area.

⚠ WARNING Risk of injury due to aggressive, hazardous residue and deposits

Chemical burn and poisoning upon contact.



- Conveyed medium forms deposits in the fan and ductwork that can cause adverse health effects.
- ▶ Wear suitable personal protective equipment.
- ▶ Observe the Safety Data Sheet(s) of the conveyed medium.
- ▶ For leaking condensate: neutralize, immediately wipe up, and dispose of in accordance with current local regulations.

3.8 Dangers due to insufficient safety

⚠ WARNING Risk of injury due to missing or non-functioning safeguards



- Safeguards on fan: Isolation switch, splinter protection, protective grid for free sucking/blowing installation.
- Hood (belt guard) for V-belt drive.
- ▶ Regularly inspect safeguards for function and damage.
- ▶ Replace missing or damaged safeguards immediately.

3.9 Actions to take in an emergency

Explosion or melting of the plastic components during fan operation constitutes an emergency situation.

Possible causes (due to use in a manner other than that intended):

- Mechanical damage to the impeller due to foreign objects or speeds above the permissible limit.
- Prohibited chemical or thermal factors (compare with technical data sheet).

Possible consequences:

- Parts ejected from the fan with high force.
- Casing explosion.
- Escape of conveyed medium.
- Development of hot, corrosive, hazardous, or flammable gases.

⚠ WARNING Risk of injury due to damaged fan



- Fan can continue coasting for a long time after being switched off.
- Danger by contact with dangerous parts and conveyed medium if casing is damaged.
- ▶ Use caution when approaching the fan.
- ▶ Observe the Safety Data Sheet(s) of the conveyed medium.

If no emergency measures are directed by the operator, proceed as follows:

1. Use the isolation switch to remove voltage on all phases.
2. Get personnel who are injured or in danger to safety. Get personnel who are having difficulty breathing to fresh air immediately.
3. Perform first aid.
4. Alert rescue/emergency personnel and inform them of the hazards of the conveyed medium according to the Safety Data Sheet.
5. Safeguard the hazardous area.
6. Fight small incipient fires only with fire extinguishers approved for low-voltage electrical equipment and the conveyed medium.

⚠ WARNING Risk of burn, risk of poisoning from smoke inhalation



Burns, damage to respiratory tract.

- The thermoplastic of the fan generates smoke when burnt.
- If the fan housing is made of PVC, there will be adverse health effects and caustic smoke when burnt.
- ▶ Maintain a safe distance when extinguishing.
- ▶ Pay attention to the direction in which the smoke is spreading.

⚠ WARNING Danger of asphyxiation with carbon dioxide (CO₂) fire extinguisher use



- There could be a high concentration of carbon dioxide (CO₂) in the breathing air.
- ▶ Do not attempt to extinguish in confined, small, or enclosed spaces.
- ▶ Instead, fight fire from outside through open door.
- ▶ Do not access area where fire occurred until it has been thoroughly ventilated.

4 Structure and function

4.1 Overview

4.1.1 Execution with V-belt drive

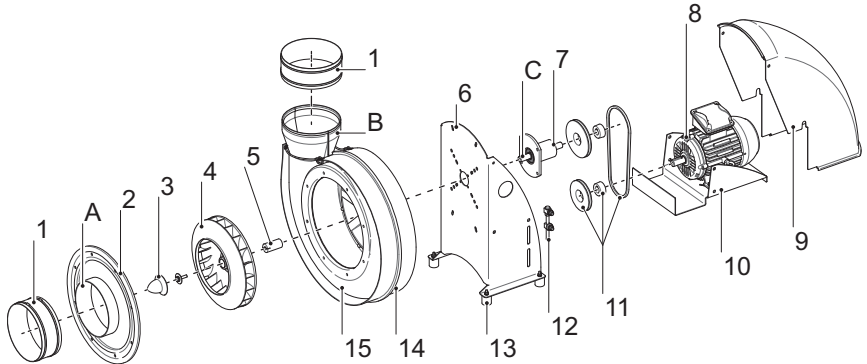

Fig. 2: Fan overview

- 1 Sleeve (2x): Stress-free connection of the inlet (A) and outlet (B) connections to the connection tubes.
- 2 Inlet cover with sealing ring, removable: Directs the conveyed medium through the inlet connection (A) into the fan. Serves as maintenance opening.
- 3 Hub cap: Seals clamping adapter (5) and motor shaft (C) from contact with the conveyed medium.
- 4 Impeller: Forward-curved impeller blades, balanced.
- 5 Clamping adapter set: Fixes the impeller (4) to the motor shaft (C).
- 6 Support
- 7 Flange bearing
- 8 Electric motor
- 9 Hood: cover for V-belt drive
- 10 Motor bracket
- 11 V-belt drive, consisting of drive belt, belt pulleys, and taper lock bushings
- 12 Adjusting screws: for tensioning/setting the drive belt
- 13 Vibration absorber: Absorbs damaging vibration and serves for fastening the fan.
- 14 Splinter protection: Prevents fragments from being ejected in the event of impeller breakage.
- 15 Casing

Function description

In the centrifugal fan, a gaseous medium is drawn in through the inlet connection in the direction of the motor axis and deflected radially by the rotating impeller.

The mechanical energy supplied by the electric motor causes an increase in pressure and speed of the conveyed medium. The spiral-shaped casing directs the conveyed medium to the outlet connection.

4.2 Signs and warning symbols on the fan with V-belt drive

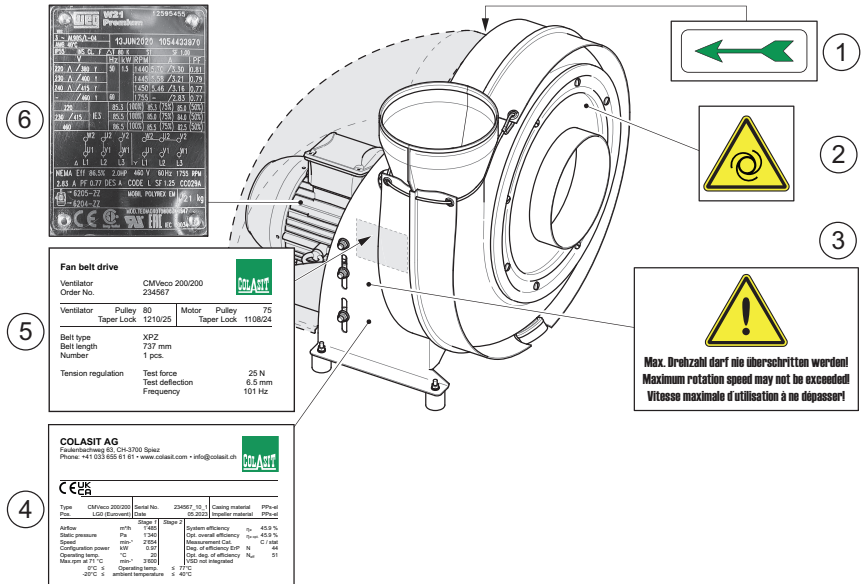

Fig. 3: Signs and warning symbols on the fan

- | | |
|-------------------------------------|----------------------------|
| 1 Direction of rotation arrow | 4 Fan nameplate |
| 2 "Automatic start-up" warning sign | 5 V-belt drive plate |
| 3 "Maximum speed" warning sign | 6 Electric motor nameplate |

The operator's responsibilities regarding these signs on the fan are to

- keep them clean and uncovered,
- replace them if damaged or missing.

4.3 Options and accessories

4.3.1 Vibration absorbers

Vibration absorbers (round isolators) for floor and wall mounting

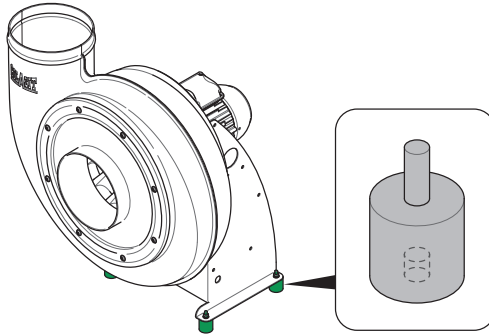

- **Required accessory.**
- For mounting the fan on the floor ⇒ Chap. 6.6 [► 35] or on a wall bracket Wall mounting.
- Dampens vibration and prevents operating faults.
- Designed for permissible fan vibration according to ISO 14694.

Fig. 4: Vibration absorbers for floor and wall mounting

4.3.2 Sleeves

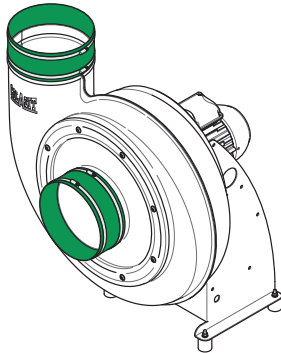

- **Required accessory.**
- For flexible connection of the inlet and outlet connections to straight ductwork.
- Sleeves inhibit the transfer of mechanical loads to the fan housing.
- Attach with hose clamps.
- Executions: See accessories for the CMVeco 125-400 on the manufacturer's website (www.colasit.com).
- Permissible distance between fan connection and ductwork ⇒ Chap. 6.8 [► 37].

Fig. 5: Sleeve installation locations

4.3.3 Sleeves with flange

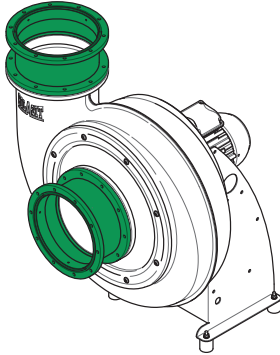

Fig. 6: Sleeves with flange

- **Required accessory for fans with flange connections.**
- For flexible connection of the inlet and outlet connections to ductwork with flange connections.
- Executions: See accessories for the CMVeco 125-400 on the manufacturer's website (www.colasit.com).

4.3.4 Flange connections

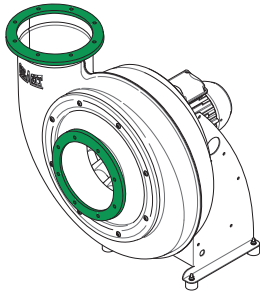

Fig. 7: Flange connections

- Optional.
- Inlet and outlet connections with flange connection.
- Executions: See accessories for the CMVeco 125-400 on the manufacturer's website (www.colasit.com).
- Sleeves with flange required
⇒ Chap. 4.3.3 [► 25].

4.3.5 Condensate drain

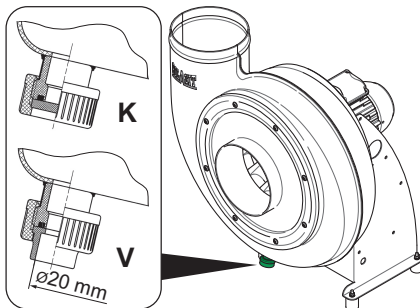

Fig. 8: Casing drain on condensate drain

- Optional.
- For draining of condensate.
- Executions:
 - “K” for manual draining with cover cap.
 - “V” for connection to siphon. Suitable for socket welds.
- For instructions on retroactive mounting as well as siphon dimensioning ⇒ Chap. 6.9 [► 39].

4.3.6 Isolation switch

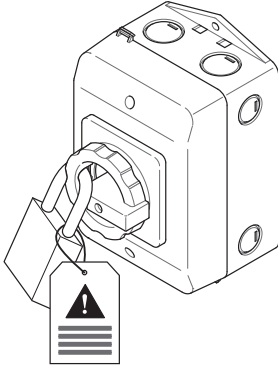

Fig. 9: Isolation switch

- **Required accessory.**
- For removal of voltage on all phases before maintenance and repair work.
- Can be locked in the OFF position with a customer-supplied padlock.
- Note: The isolation switch is also referred to as a maintenance switch.

4.3.7 Frequency converter (FC)

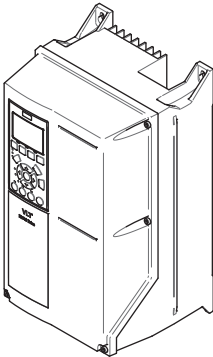

Fig. 10: Frequency converter (example)

- Optional accessory.
- For fan speed control.
- FC installation options ⇒ Chap. 7.3.1 [► 43].
- EMC-compliant wiring ⇒ Chap. 7.3.3 [► 45].
- FC parameterization ⇒ Chap. 7.3 [► 43].

4.3.8 Speed adjustment potentiometer

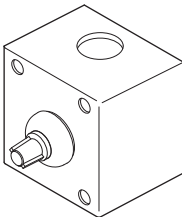

Fig. 11: Speed adjustment potentiometer (example image)

- Optional accessory.
- For setting the nominal speed on the frequency converter (FC) according to the technical data sheet.
- FC parameterization ⇒ Chap. 7.3 [► 43].

4.3.9 Wall bracket

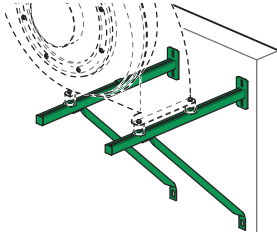

Fig. 12: Wall bracket

- **Required accessory for wall mounting.**
- Executions: See accessories for the CMVeco 125-400 on the manufacturer's website (www.colasit.com).
- For mounting instructions ⇒ Chap. 6.7 [► 36].

4.3.10 Protective grid

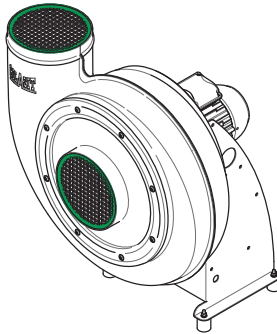

Fig. 13: Protective grid

- **Required accessory for free sucking and/or blowing installation**, as access and safety protection.
- Gets permanently installed (welded) to the free-sucking inlet connection and/or to the blowing outlet connection.
- Entry protection as well as protection against infiltration of contamination and foreign objects (IP20 degree of protection).
- **NOTICE** Protective grid not suitable for connection to ductwork (increased pressure loss).

4.3.11 V-ring hub seal

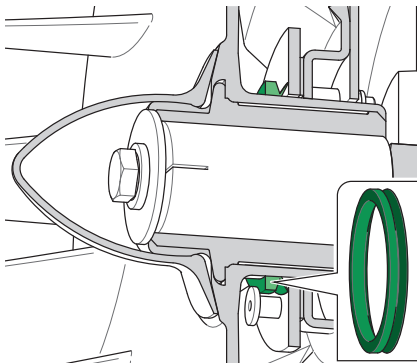
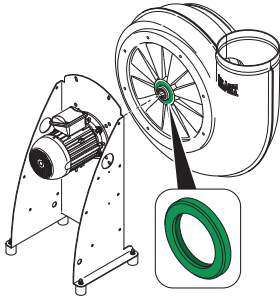

Fig. 14: V-ring hub seal

- Optional.
- Use with hazardous, aggressive conveyed media when the fan is operated in an overpressure condition.
- Wear part
- For mounting instructions ⇒ Chap. 11.9 [► 71].

4.3.12 Hub seal felt ring



- Optional.
- Use with hazardous, aggressive conveyed media when the fan is operated in an overpressure condition.
- Wear part
- For mounting instructions
⇒ Chap. 11.10 [► 72].

Fig. 15: Hub seal felt ring

4.3.13 Impeller back-plates

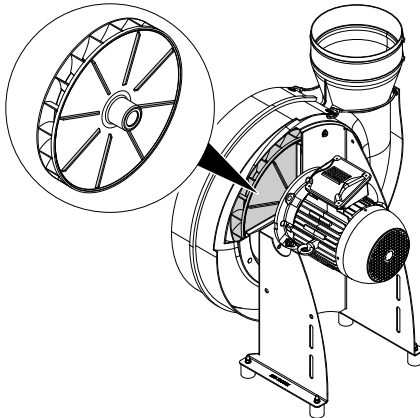

- Optional.
- Used in combination with a hub seal and/or in high humidity.
- Impeller back-plates are welded onto the impeller before balancing.

Fig. 16: Impeller back-plates

5 Transport

5.1 Safety instructions

These safety instructions warn against dangers that can arise when transporting the fan.

⚠️ WARNING Danger to life when remaining under suspended loads

Injuries due to falling or swinging loads.



- ▶ Avoid hazardous area under the suspended load.
- ▶ Never stand under or in swinging range of suspended loads.
- ▶ Maintain a safe distance from suspended loads.
- ▶ Do not leave suspended loads unattended.

⚠️ WARNING Risk of injury due to packing pieces falling or tipping over

Bruising and contusion injuries.

SAFETY INSTRUCTIONS



- ▶ Wear personal protective equipment.
- ▶ Only use hoisting gear, load handling attachments, and slings that are undamaged, approved, and have suitable load-bearing capacity.
- ▶ Use all attachment points provided, and observe the center of gravity ⇒ Chap. 5.5.1 [▶ 30]. Exception: **The lifting eye bolt on the electric motor is not an attachment point for transport.**
- ▶ Do not place slings on sharp edges or corners, and do not knot or twist them.
- ▶ The transport route must be free of obstacles and safeguarded in accordance with local regulations.

NOTICE Risk of damage due to improper transport

Damage to the fan and other material damage.



- A package with a center of gravity that is off center can tip, swing out, or fall down when lifted.
- ▶ Use provided attachment points.
- ▶ Use additional transport aids as transport protection.
- ▶ Lift package cautiously.
- ▶ Avoid rocking and swinging movements during transport.

5.2 Incoming goods inspection

For the delivered fan:

- Check for completeness based on the shipping documents.
- Inspect for possible transport damage.

If transport damage is detected:

1. Do not receive delivery, or doing so only conditionally.
2. Record transport damage (photos).
3. Note the extent of the damage on the transport paperwork or on the transport company's bill of lading.
4. File a complaint immediately.



Claims for damages can only be made within the complaint period and according to the general terms and conditions (T&C). Save packing for a possible return shipment.

5. Mount fan and place in service only after repairs and resolution of complaints.

5.3 Packing

The packing and provided transport protection protect the fan from transport damage and environmental influences.

Do not damage the packing, and remove it only shortly before mounting.



Disposal instructions

The transport packing is intended as disposable packing and is to be disposed of after use according to current local disposal instructions.

5.4 Intermediate storage

Pack the fan in the original packaging as follows:

- Covered, dry, and dust-free location.
- Protect from sun, weather, and condensation.
- Storage temperature +10 °C to +50 °C with max. 50 % humidity.

Measures for longer intermediate storage

After every 3 months of storage time, turn the impeller several rotations to prevent bearing damage.

5.5 Transport to installation location

Provide suitable hoisting gear and load handling attachments for transport.

5.5.1 Transport by crane

Transporting package with lifting eye bolts

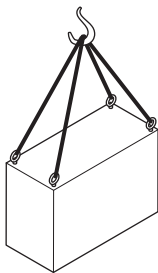

- Position crane hook over the middle of the package.
- Attach sling to all lifting eye bolts of the packing.
- **WARNING** Do not lift the fan by the lifting eye bolt of the electric motor.
- Check: Slings are not twisted. Sling legs and bends are in permissible positions.
- Lift package slightly and check that it hangs level.

Fig. 17: Package with lifting eye bolts

- Let down and adjust a package that doesn't hang level: Shorten or lengthen legs on one side appropriately until all legs are loaded equally.

Transporting package on a pallet

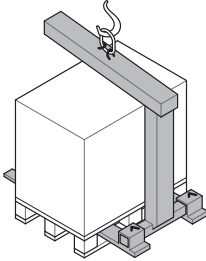

- Inspect pallet: A damaged or rotted pallet may not be transported by crane.
- Preferably, transport pallet by crane fork or pallet jack.
- Otherwise, attach sling to pallet such that it will not slip.
- Further procedure same as for as transport with lifting eye bolts.

Fig. 18: Package on transport pallet

Transporting fan with chain sling

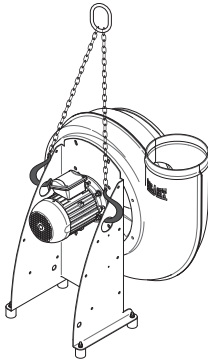

To transport an unpacked fan, use a two-leg chain sling.

- Hang chain sling as illustrated in the two large holes in the support.
- ⚠ WARNING** Do not lift the fan by the lifting eye bolt of the electric motor.
- Further procedure same as for as transport with lifting eye bolts.

Fig. 19: Fan with chain sling

5.5.2 Transport by pallet stacker or forklift

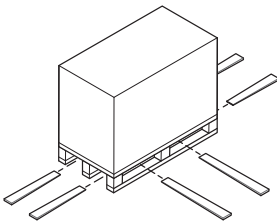

A package on a pallet can be transported by pallet stacker or forklift under the following conditions:

- Forks inserted under the pallet as depicted such that they stick out from the opposite side.

Fig. 20: Package on transport pallet

6 Mechanical installation

6.1 Safety instructions

These safety instructions warn against dangers that can arise when mounting the fan.

⚠️ WARNING Risk of injury due to unsecured work area

Injuries due to objects falling or being bumped.

- The installation location of the fan could be inaccessible or at a dangerous height.
- ▶ Set up safe means for accessing the installation location (e.g. walkway with banisters, platform).
- ▶ Safeguard work area with enclosures, safety nets, etc.
- ▶ Secure work area against unauthorized access.



⚠️ WARNING Risk of injury due to improper mounting

Injuries by pinching and crushing of body parts.

- ▶ Find out from structural or construction engineer:
 - Foundation (baseplate) - execution and load capacity.
 - Fastening elements for wall bracket, ceiling mounting.
- ▶ Safeguard fan against tipping by suitable means.
- ▶ Immediately following completion of mounting work, remove all braces, supports, etc.



⚠️ WARNING Risk of injury due to escape or inflow of a conveyed medium with the ability to cause adverse health effects

Risk of eye irritation, cough, difficulty breathing, burn, and suffocation.

- ▶ Wear protective equipment.
- ▶ Close shut-off damper to inlet and outlet connections until all installation work is complete.
- ▶ Watch for escaping conveyed medium as well as deposits and condensate when using the service opening and inspecting the ductwork.



6.2 Installation location requirements (only for BD)

📢 NOTICE Risk of damage due to improper outside mounting

Material damage and production downtime.

- ▶ Use platform for installation sites with poor drainage.



Foundation (baseplate) or mounting surface shall meet the following requirements:

- Vibration resistant
- Flat surface
- Suitable for absorption of static and dynamic loads.
 - For calculations for the mounting parts, assume four times the fan weight.

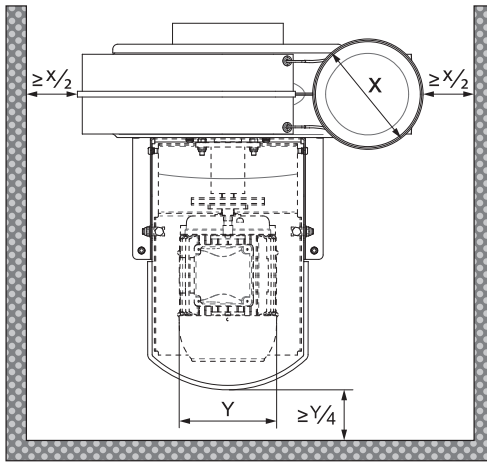

- Provide suitable clearance around the fan for
 - maintenance and repair work,
 - motor cooling.

Fig. 21: Space requirement for work area for fan with V-belt drive

Dimensioning notes



The minimum distance at the installation site for the hood of the V-belt drive must be larger than one fourth the diameter (Y) of the fan cowl of the electric motor.

6.3 V-belt drive – check proper mounting

NOTICE Risk of damage due to improper mounting

Proper belt tension is a prerequisite for error-free power transmission and for achieving the belt's rated service life.

- Improper belt tension leads to a reduction in the fan's functionality and to early failure of the belt.
- An overtensioned drive belt often will also damage the bearing on the electric motor.
- ▶ The drive belt shall correspond to the information on the belt plate.
- ▶ The V-belt drive shall always be guarded against access with the supplied hood.



The settings for the V-belt drive are

- specified on the belt plate and
- depend on the belt type and are specific to the fan supplied.

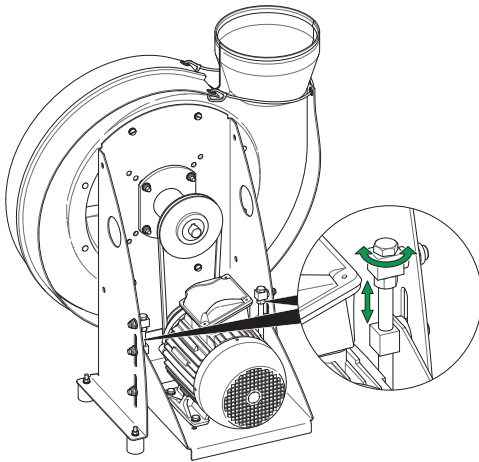

Fig. 22: Checking the V-belt drive

Procedure:

1. Remove the hood.
2. Check the belt tension of the drive belt. See the belt plate for the settings
⇒ Chap. 4.2 [► 23].
3. Tension the drive belt if necessary
⇒ Chap. 11.12 [► 74].
4. Mount the hood again.

6.4 Splinter protection - check proper mounting

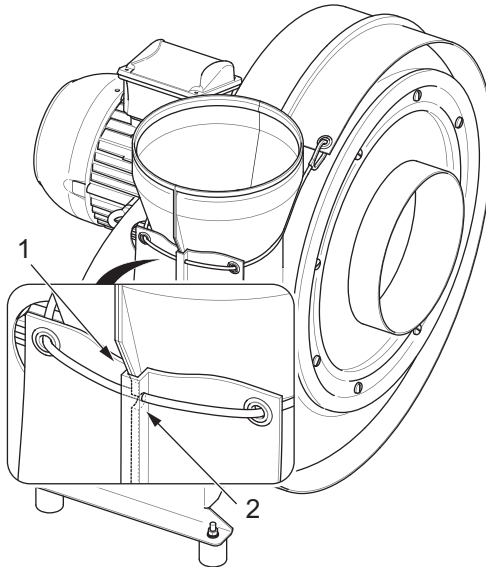

Fig. 23: Proper mounting of the splinter protection

Check proper mounting of the splinter protection:

- The groove in the splinter protection lies along the welding edge (1) of the casing.
- The rubber band lies in notch (2) on the welding edge.
- Snap hooks are hooked through the eyelets.

6.5 Mounting the vibration absorbers (only for BD)

⚠ WARNING Risk of injury due to fan falling down or falling over

Injuries by pinching and crushing of body parts.



- Undersized vibration absorbers can come off.
- Fans with a V-belt drive are not suitable for ceiling mounting.
- ▶ Use the supplied vibration absorbers.
- ▶ Externally sourced vibration absorbers shall be equivalent.
- ▶ Only replace vibration absorbers with identical components during maintenance work.

NOTICE Risk of damage due to vibration



Material damage and production downtime, reduced service life.

- Missing or improperly sized vibration absorbers lead to damage of the motor, impeller, and installation site.
- ▶ Always mount fan with suitable vibration absorbers.
- Mount suitable vibration absorbers on the mounting holes of the support.
- Select the vibration absorbers according to the following table in consideration of the installation position and the size or total weight of the fan
⇒ Chap. 4.3.1 [▶ 24].

Suitable vibration absorbers (round isolators) for floor/wall mounting

Fan/size	Type of round isolator for floor/wall mounting	Connection thread	Load capacity [kg/pc]	Shore hardness [A]	Quantity [pc]
CMVeco 125-200	Type B Ø30 x 30	M8 x 20	50	68	4
CMVeco 250-400	Type B Ø40 x 40	M8 x 23	88	68	4

6.6 Floor mounting

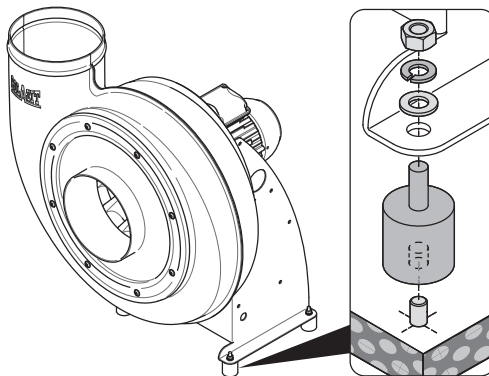

Conditions:

- Installation location requirements ⇒ Chap. 6.2 [▶ 32].
- Round isolators and fastening elements present.

Fig. 24: Fastening recommendation for floor mounting

1. Transfer fan support hole pattern to the foundation (baseplate).



Hole pattern dimensioning according to technical data sheet.

2. Install anchoring elements (anchors) according to supplier's instructions.
3. Fix round isolators to anchoring elements.
4. Set fan on round isolators and fasten tightly.

6.7 Wall mounting (only for BD)

⚠ DANGER Risk of injury due to fan falling

Injuries by pinching and crushing of body parts.



- Never mount fan support vertically on the wall!
- ▶ Only mount the fan with wall bracket ⇒ Chap. 4.3.9 [▶ 27].
- ▶ Tightly screw in and secure all screw connections.

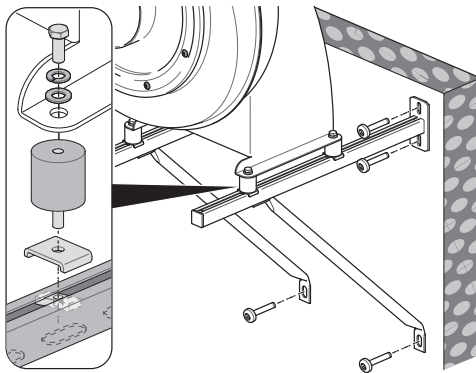

Conditions:

- Installation location requirements ⇒ Chap. 6.2 [▶ 32].
- Wall bracket shall be designed for four times the fan weight.
- Fastening elements present.

Fig. 25: Fastening recommendation for wall mounting

1. Transfer hole pattern from wall bracket with support braces to wall.
2. Install anchoring elements (anchors) according to supplier's instructions.
3. Fix wall bracket to wall with support braces (at 45° bracing angle).
4. Pre-assemble vibration absorbers to wall bracket.
5. Set fan on vibration absorbers and align and fasten per dimension H of the following table.

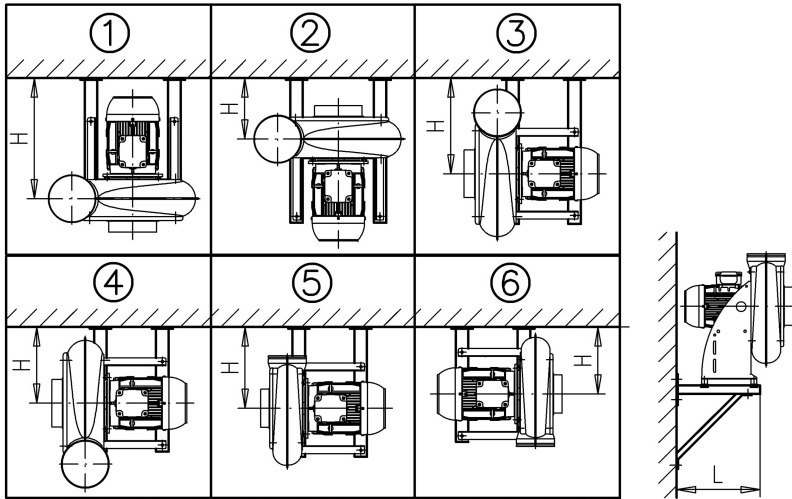

Fig. 26: Mounting position on the wall bracket

Series	[mm]	1	2	3	4	5	6
CMVeco 125	L	500	500	500	500	500	500
	H	440	180	310	270	300	290
CMVeco 160	L	500	500	500	500	500	500
	H	530	180	330	290	300	300
CMVeco 200	L	750	750	750	500	750	750
	H	630	290	470	290	440	440
CMVeco 250	L	750	750	750	750	750	750
	H	700	290	490	420	450	450
CMVeco 315	L	1000	750	1000	750	1000	1000
	H	810	280	640	450	580	600
CMVeco 400	L	1000	1000	1000	1000	1000	1000
	H	900	400	670	560	580	610

6.8 Connecting fan to ductwork

NOTICE Risk of damage due to deformation of fan housing

Impeller touches casing or inlet cover.

- Connection tubes attached directly to fan connections transmit prohibited stresses to the fan housing, e.g. due to thermal expansion.
- ▶ Only connect fan connections to ductwork with sleeves.
- ▶ Mount sleeves properly.



NOTICE Risk of damage due to lateral forces

Cracking of the sleeve.



- Sleeves can only minimally compensate for a lateral/radial duct misalignment.
- ▶ Align connection tubes precisely.
- ▶ Use supports for supplemental securing of connection tubes.



A detachable duct section (1, see image) is provided at the inlet connection for maintenance and repair work on the impeller. The length of the duct section shall correspond to at least the diameter of the inlet connection or the fan size.

Check beforehand:

- Turn the impeller by hand and check that it is smooth running.
 - Adjust the impeller if it contacts other surfaces ⇒ Chap. 11.8 [▶ 69].
- Check the fan and ductwork for tools left behind, mounting residues, or foreign objects.

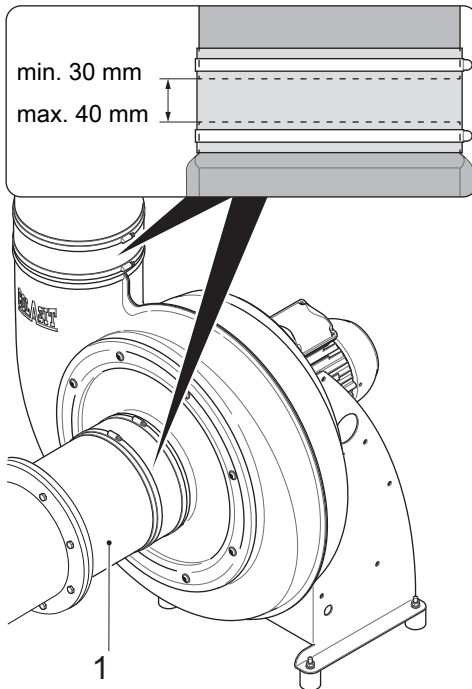

Procedure:

1. Push the sleeve ⇒ Chap. 4.3.2 [▶ 24] over the ductwork end together with the hose clamps.
2. Mount the ductwork and adjust it to the fan connection.
3. Observe the permissible distance (see detail view).
4. Push the sleeve onto the ductwork end and fan connection equally, and secure it with hose clamps.
5. Check that the sleeve has been mounted in a flexible, stress-free manner.

Fig. 27: Distance to ductwork connection



As alternatives, Wellflex sleeves or sleeves with two-sided flanges ⇒ Chap. 4.3.3 [▶ 25] are available (use in zone 2 environment if the piping is still in the explosion protection zone).

6.9 Connecting condensate drain to siphon

NOTICE Environmental damage due to toxic condensate



- ▶ If possible, direct condensate downstream of the siphon back into the process.
- ▶ Collect condensate in the collecting container and dispose of according to regulations.

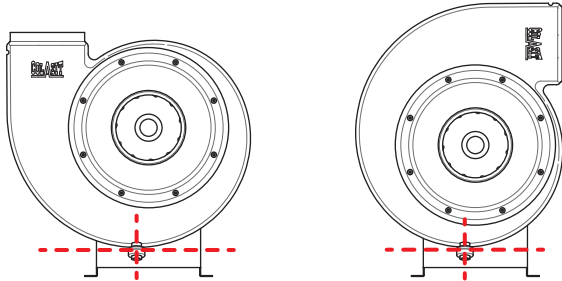

Fig. 28: Proper position of the casing drain



The casing drain shall always be located at the lowest point of the fan housing's current mounting position. When mounting as a retrofit, an opening for the casing drain shall be cut in the splinter protection.

- Weld drain pipe (outer diameter 20 mm) to casing drain (type V)
⇒ Chap. 4.3.5 [▶ 25].
- Connect drain pipe to siphon.

6.9.1 Siphon calculations and execution

Required siphon height and installation height

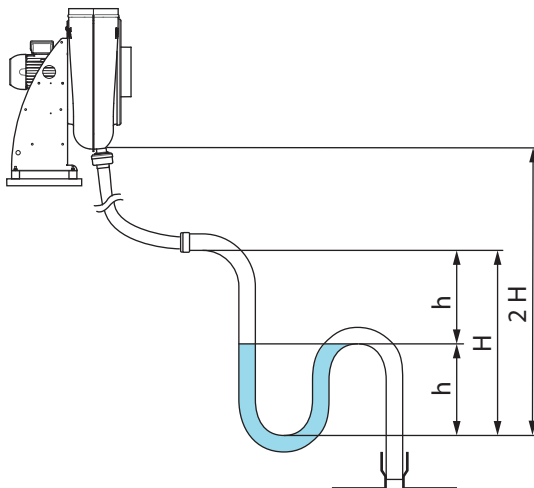

Fig. 29: Siphon height and installation height

**Calculation formula with
SI units:**

$$h = \frac{p_{stat}}{10} + 15$$

$$H = 2 \cdot h = 2 \cdot \frac{p_{stat}}{10} + 30$$

Legend:

h = min. siphon height [mm]

p_{stat} = static fan pressure [Pa]

H = installation height [mm]

Siphon height [mm]:

At least 1/10 of the maximum static fan pressure p_{stat} [Pa].

Height difference between casing drain and siphon overflow:

If the siphon height "h" is not observed, the condensate will not drain and will be directed to the fan.



When planning for and mounting the siphon, observe a minimum installation height of 2 x H.

Instructions for execution of the siphon

- For negative pressure operation of the fan: If the siphon is insufficiently dimensioned or not filled with water, there is a risk that false air will be sucked in.
- Ensure functionality of the siphon: It is imperative to fill it with water before placing in service or after an extensive downtime period.
- For outside mounting, ensure frost-resistant execution of condensate drain and siphon.
- If there are space limitations (siphon height), mount siphon in a floor opening.

6.10 Final inspection

- Check that all screw connections on the fan and all fastening elements of the foundation (baseplate) or mounting surface are tight.
- Inspect splinter protection ⇒ Chap. 6.4 [▶ 34].
- If present in ductwork:
 - Shut-off dampers for inlet and outlet connections are closed.
 - Service openings are shut.

7 Electrical installation

7.1 Safety instructions

These safety instructions warn against dangers that can arise during electrical installation of the fan.

⚠ DANGER Risk of injury due to electrical energy

Immediate danger to life due to respiratory and cardiac arrest.

- Erroneous or insufficient execution of the electrical connections, the wiring, and the cable routing as well as the electrical safeguards of the fan.
- ▶ Only authorized, qualified electricians may carry out the electrical installation and connect the fan to the power supply.
- ▶ The electrical installation is to be executed in accordance with the standard EN 60204-1, the technical connection requirements, and the relevant regulations.



⚠ WARNING Trip and fall hazard due to cables run along the floor

Bruises and other injuries.

- ▶ Motor connection cables run along the floor are to be run properly and protected by a cover.
- ▶ Indicate the trip hazard with floor markings.



⚠ WARNING Risk of electrical shock due to electrostatic charge

Subsequent injuries due to response upon being startled.

- As a precaution, take protective measures against electrostatic charge when operating the fan.
- ▶ Ground the fan support.
- ▶ For outside mounting, connect the fan support to the lightning protection system.



⚠ CAUTION Electrical hazards due to improper layout/undersizing of the electric motor and protective devices.

Operation outside of the specified characteristic curves.

- ▶ The application limits of the electric motor must be greater than or equal to the application limits of the fan.
- ▶ Size electrical protective devices according to the electric motor and connection cables.
- ▶ Operate only within the specified characteristic curves (flow rate and differential pressure) according to the technical data sheet.



7.2 Electrical protective devices

7.2.1 Isolation switch installation

Improper use of isolation switch



The isolation switch is only a protective device for disconnecting the fan from electrical power during mounting, maintenance, or repair work and not to turn the fan on and off in the context of operation.

The isolation switch

- is a required protective device,
- shall be installed in an easily-accessible location near the fan,
- provides qualified personnel a means of directly controlling and disconnecting the electrical power supply from the fan,
- shall therefore be executed as a lockable all-pole disconnect switch.

7.2.2 Motor protection switch installation

An electric motor with a nominal power rating over 0.5 kW is to be protected against overload and connected to the electrical power supply with a motor protection device (overload and short circuit protection) suitable for this.

NOTICE Risk of overheating of the electric motor

Damage to motor

The motor protection switch does not reliably protect the electric motor from overheating, particularly with insufficient motor cooling due to low speed, defective fan impeller, or clogged ventilation grid.

- ▶ The installation of a motor protection switch is the responsibility of the operator.
- ▶ Specify the motor protection switch based on the motor rated current on the nameplate.



If a frequency converter (FC) is used, clarify whether integrated motor protection functions allow for fan operation without an additional motor protection switch.

The FC is to be parameterized with the motor data by qualified personnel.

7.2.3 Starting current limiter

NOTICE Strong mechanical load by the fan. Thermal and electrodynamic load on the motor windings.

Reduced service life of the fan.

Disturbance of nearby electrical equipment, such as controllers.

- When larger fans are switched on and ramped up under full mains voltage, a high inrush current is generated.
- When the fan is started directly, excessive torque occurs that can severely stress and damage the impeller and motor bearings.
- ▶ The manufacturer recommends the use of a starting current limiter starting with motor ratings of 3 kW (e.g. star-delta starter, soft starter, or soft start with frequency converter (FC)).

At the latest, for fans with a motor rating above 4 kW, the starting current is to be limited by one of the listed methods or equipment:

- Star-delta start-up
- Soft start/soft starter
- FC with current-limiting and start-up characteristics.



Observe the national regulations and limit values of the power system operator for direct start-up of three-phase motors.

7.3 Instructions for frequency converter (FC) use

⚠ DANGER Risk of injury due to impeller explosion

Serious injuries due to debris being launched out.



- Exceeding the maximum speed after a malfunction or faulty operating condition of the frequency converter.
- ▶ Splinter protection shall be mounted on the fan ⇒ Chap. 6.4 [▶ 34].
- ▶ The manufacturer recommends using a frequency converter with an integrated SLS safety function.
- ▶ Alternatively, implement higher-level drive control with an SLS safety sub-function.



The SLS (Safely Limited Speed) safety function prevents the electric motor from exceeding a specified speed limit.

⚠ WARNING Risk of injury due to high contact voltage

Injury by electric shock.



- If long cable shields are not connected/grounded, high contact voltages can occur during operation.
- ▶ Connect cable shields of motor connection cables and signal lines to a common reference potential.
- ▶ Do not use protective earth connections for shielding purposes.

⚠ WARNING Risk of injury due to dangerous residual voltage

Injury by electric shock.



- After the fan has been switched off, dangerous residual voltage is still present in the frequency converter.
- ▶ The operating instructions of the frequency converter provide information about the time to be observed until this residual voltage has dropped to a safe value.
- ▶ Before beginning work on the electrical components, always establish an electrically safe work condition of the frequency converter.

7.3.1 Frequency converter (FC) installation options

For CMVeco 125-400 type centrifugal fans, different executions of electric motors (IM, PM, EC) can be selected as a drive:

- IM ... Standard asynchronous motor/three-phase motor
- PM ... Permanent magnet motor
- EC ... Brushless DC motor

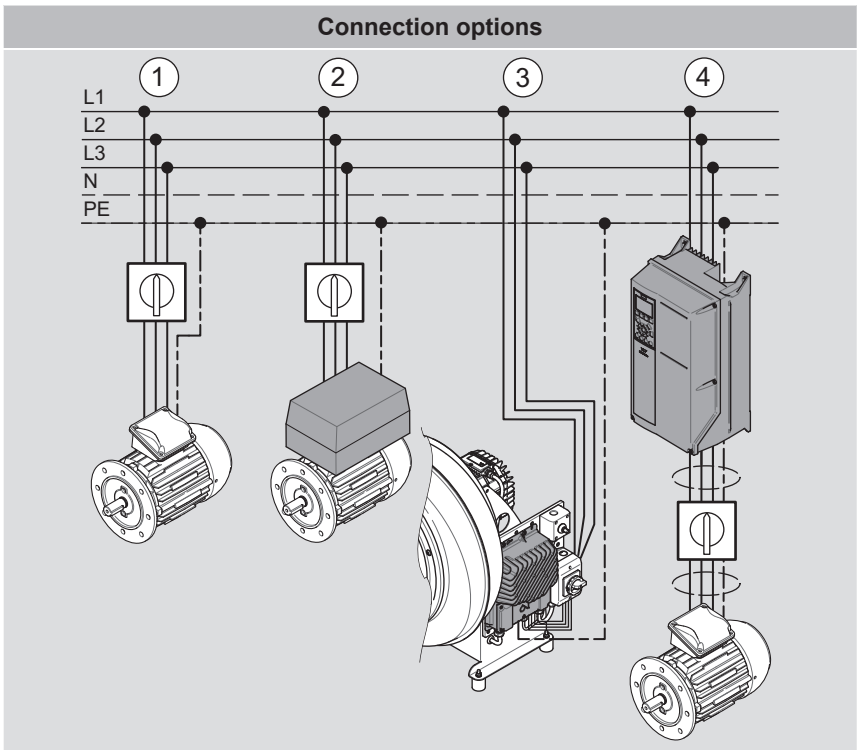

Depending on the execution, an electric motor can either be connected directly (1) to the electrical mains or can/shall be operated with a FC.



L2 and L3 do not exist for a single-phase feed (230 V).

The FC is either

- directly attached to the electric motor (2, order option),
- mounted on the fan support (3, order option),
- or installed separately (4, customer solution).

NOTICE Risk of damaging the frequency converter



Do not manipulate the isolation switch when the electric motor is running if connection option 4 is used.

7.3.2 Frequency converter (FC) parameterization

NOTICE Risk of damage due to erroneous parameterization

Unpredictable fan behavior resulting in damage.

- ▶ Carry out parameterization carefully according to the FC operating instructions. The specialist shall be familiar with the FC. If necessary, consult the supplier.
- ▶ For basic setup, enter the motor data according to the nameplate on the electric motor.
- ▶ Enter the maximum frequency/speed limit according to the fan nameplate or technical data sheet.
- ▶ Enter the acceleration and braking times with regard to the following table.
- ▶ Record the parameters that were entered.

To prevent mechanically overloading the fan, observe these minimum permissible acceleration and braking times:

Electric motor nominal power [kW]	Acceleration/braking time [s]
< 1.5	min. 15
> 1.5	min. 30



To avoid an FC error message, a longer acceleration/braking time could be necessary.



Parameterization for PM motors

Parameterization for PM motors differs significantly from three-phase motors. The FC and motor manufacturers offer support for this.

7.3.3 Connecting the electric motor to a frequency converter (FC)

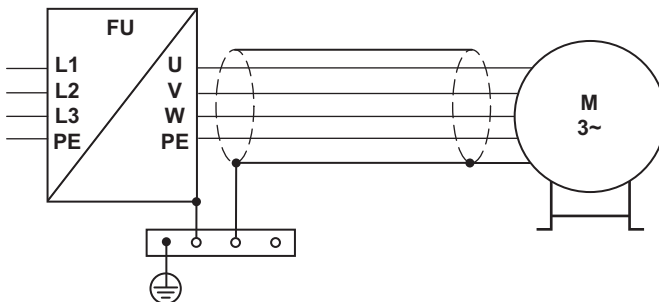

Fig. 30: Connection principle for short motor cable (FC close to fan)

EMC-compliant connection for FC operation



Observe the EMC instructions of the fan manufacturer as well as the operating instructions of the FC manufacturer.

In particular, the maximum permissible length of the motor connection cable between the FC and the electric motor as well as the corresponding grounding concept.

1. If possible, connect the cable shield of the motor connection cable directly to the FC output with a grounding bar.
2. Install the isolation switch in the EMC execution and/or ATEX execution given in the guidelines of these operating instructions.

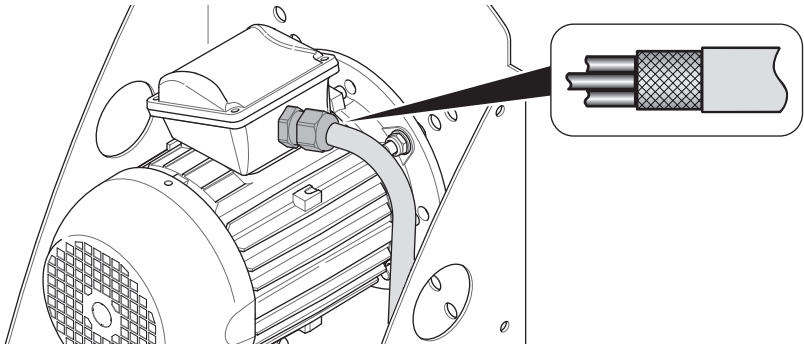

Fig. 31: EMC cable gland

3. Secure the motor connection cable to the motor terminal box with an EMC cable gland.
 - Strip the cable end appropriately so that contact can be made with the cable shield.
4. Connect the motor connection cable to the electric motor
⇒ Chap. 7.4 [► 46].

7.4 Connecting the electric motor

This chapter describes the direct connection of a three-phase motor (IM) to the electrical power supply (connection option No. 1 in overview
⇒ Chap. 7.3.1 [► 43]).

For instructions on connection to a frequency converter ⇒ Chap. 7.3.3 [► 45].

Sizing and installing the motor connection cable

Adequately size the cross section of the motor connection cable, taking into account:

- Applicable standards and regulations
- Cable lengths
- Rated current
- Environmental conditions
- Type of installation



To size the connection cable, consult the cable manufacturer's tables for current-carrying capacity or request sizing information directly from the cable manufacturer.

When running the cable, observe the following essential principles:

- Avoid damaging the cable by pinching, cutting, pulling, etc. during installation.
- Run connection cables in the building securely with clamps or mounting brackets, and protect them from damage with cable conduit.
- For protection against vibration, run the connection cable between the fan and cable fasteners to the installation location such that it is flexible and movable.

Making the cable connection

- **⚠ DANGER** Establish an electrically safe work condition before beginning work.
- Connect the connection cable to the motor protection switch/fuses and the isolation switch.
 - Ensure correct connection of the phase conductors.
 - Seal all cable entries such that they are splash-proof.
- Compare the mains voltage and mains frequency with the information on the motor nameplate and determine the connection type of the electric motor (delta or star connection).

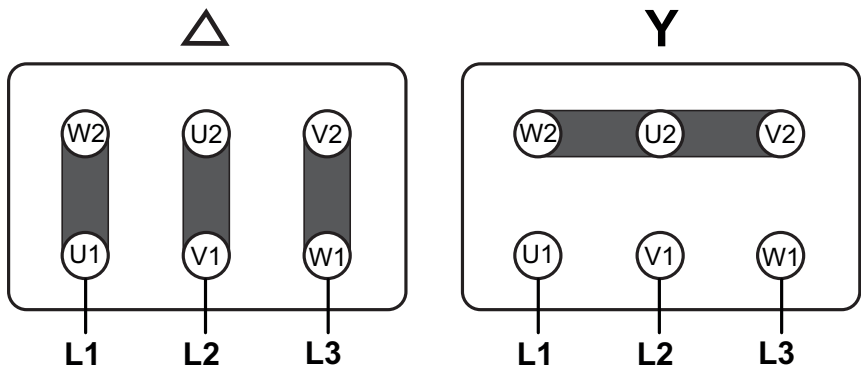

Fig. 32: Terminal assignment for delta and star connection

- Open terminal box on electric motor.
- If necessary, move the jumpers on the terminal board according to the terminal assignment.



The terminal assignment is also located on the inside of the terminal box cover.

- Connect the phase conductors (L1, L2, L3) of the motor connection cable to the terminal board in the correct order.

- Use insulated ring terminals for phase conductors.
- Attach the protective earthing (PE) to the protective earthing connection in the terminal box using a ring terminal and serrated lock washer.
- Check:
 - Cable gland on the terminal box is suitable for the diameter of the connection cable.
 - All unused cable inlets on the terminal box are sealed watertight with blind plugs.
 - Sealing ring and sealing surface on the terminal box are clean.
- Close terminal box.

7.5 Mounting the hood on the V-belt drive (only for BD)

After completion of the electrical installation work, the hood shall be installed on the fan with V-belt drive.

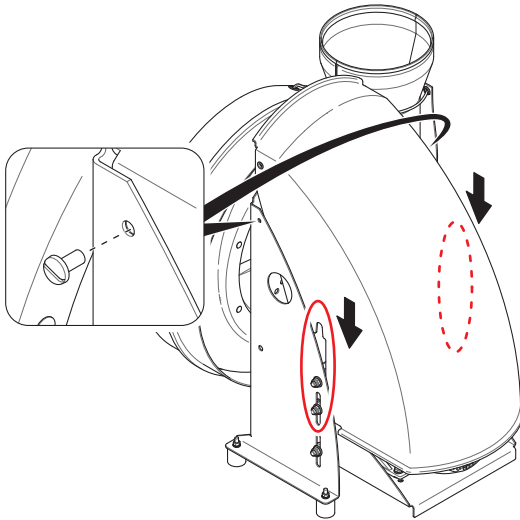

Fig. 33: Mounting the hood (BD)

- Fasten the hood to the support as depicted.

7.6 Final inspection

- Verify mains and motor connections with motor nameplate data.
- Check the sizing and setting of the electrical protective devices (fuses, motor protection switch).
- Check installation of motor connection cable and isolation switch.
 - Three-phase mains voltage is applied to the line side of the isolation switch.
- Check connections of protective earthing (PE) and grounding for fixed position and for execution compliant with standards.
- If frequency converter (FC) is used:

- Check FC terminal assignment, shield connection, and cable strain relief.
- Check and record important FC parameters and settings: Maximum output frequency, V/f characteristic curves, acceleration and braking times ⇒ Chap. 7.3 [► 43].



If required for control and placement in service, connect an external control unit to the FC.

8 Placement in service

8.1 Safety instructions

These safety instructions warn against dangers that can arise when placing the fan in service.

⚠️ WARNING Risk of injury when placing the fan in service.

Injuries due to electrical, mechanical, and chemical hazards.

- ▶ Installation work on the fan as well as final inspection have been completed in their entirety ⇒ Chap. 6 [▶ 32], ⇒ Chap. 7 [▶ 41].
- ▶ Initial and subsequent placement in service is only to be completed by authorized mounting personnel.
- ▶ Secure the isolation switch with a personal padlock to prevent unauthorized energization until all checks and preparations have been carried out. Hang tag on isolation switch.
- ▶ For free sucking or blowing out installation of the fan:
Before energization, ensure that no one remains in the hazardous area of the inlet and/or outlet connections.
- ▶ Do not place a fan in service that is iced over. Pieces of ice can then come off and cause serious injuries and material damage. Do not remove ice from the fan forcibly or with chemical deicers.
- ▶ An electrician is responsible for energization of the fan.



8.2 Carrying out placement in service

Open the shut-off or damper valves of the fan's supply air duct and discharge duct.

8.2.1 Check motor rotation direction

Procedure:

- Briefly turn the fan on and off with the isolation switch.
- Check motor rotation direction and compare with direction of rotation arrow on the fan housing. ⇒ Chap. 4.2 [▶ 23].



To check the direction of rotation, observe the fan impeller of the electric motor or use a motor tester for non-contact determination of the direction of rotation.

- If the direction of rotation is incorrect, have an electrician switch two phase connections of the isolation switch or in the terminal box of the electric motor, or, if available, change the direction of rotation on the frequency converter.
- For fan with V-belt drive: Check belt tension ⇒ Chap. 11.12 [▶ 74].

8.2.2 Functional test of the frequency converter (FC, optional accessory)

Procedure:

- Test start/stop and acceleration behavior starting at a low frequency (25 Hz).
- Increase fan speed from minimum to maximum speed ⇒ Chap. 7.3.2 [▶ 45]

- with an external signal from the higher-level controller,
- with FC control elements or an external control unit,
- with the local potentiometer ⇒ Chap. 4.3.8 [► 26].

Check during the functional test:

- Check acceleration and braking time ⇒ Chap. 7.3 [► 43].
- Commands shall cause corresponding speed changes.
- The electric motor may not generate any unusual vibration or noises when operating within the characteristic curve range according to the technical data sheet.
- Conduct speed measurement.
 - **NOTICE** Do not exceed the maximum speed of the impeller or the maximum frequency of the electric motor according to the technical data sheet/motor nameplate.
- During start/stop operations, the FC may not display an error message or trigger a protective function.

8.2.3 Conduct test run

Run the fan at the designated operating point, or at the operating impeller speed on the nameplate, for at least 1 hour.

At the beginning of the test run:

- Check for irregular running, unusual vibration, or noises.
- Once the operating speed has been reached, the current draw of the electric motor may not exceed the nominal value according to the motor nameplate.
- Check for leak tightness and flexible mounting of the sleeves on the fan.
- Perform vibration measurement on the fan's electric motor and compare with the table for vibration limits according to ISO 14694:

Status	Category	Permissible vibration when flexibly mounted (effective value/RMS) [mm/s]
Start-up	BV-2	9,0
	BV-3	6,3
Alarm	BV-2	14,0
	BV-3	11,8
Shutdown	BV-2	*
	BV-3	12,5

* Establish based on historical limit values.



The measured data provides comparison values during maintenance.

Heating, ventilation, air conditioning (HVAC), and agriculture: BV-2 < 3.7 kW
Industrial processes, etc.: BV-3 > 3.7 kW

At the end of the test run:

- Compare current values and parameters with initial values and parameters from the beginning of the test run:
 - Irregular running, vibration, or noises.
 - Current draw of the electric motor.
 - Vibration measurement.
- Check leak tightness of the sleeves.
- Measure temperature of the electric motor and compare with information in the technical data sheet or on the nameplate.
- For fan with V-belt drive: Check belt tension ⇒ Chap. 11.12 [► 74].
- Create a test report during initial commissioning.
- Leakage value: The leakage value of the supplied fan can be requested from the distributor.

9 Operation

9.1 Safety instruction

This safety instruction warns against dangers that can arise during fan operation.

⚠️ WARNING Risk of injury due to fan operation

Injuries due to electrical, mechanical, and chemical hazards.



- ▶ Only qualified and authorized operating personnel may operate the fan and clean the outside of it.
- ▶ In the event of an operating fault, assign qualified personnel to rectify the fault.

9.2 Operating instructions

The fan is

- either operated with a higher-level, automatic control
- or manually switched on and off with operating elements on the plant side.



The operating personnel are also responsible for regularly checking the operating condition of the fan ⇒ Chap. 10.3.1 [▶ 55].

Actions to take in the event of a malfunction

1. Shut the fan down and inform supervisory personnel.
2. In case of emergency, immediately carry out emergency measures ⇒ Chap. 3.9 [▶ 20].
3. Shut down system components affected by fan failure.
4. Assign qualified personnel to rectify the fault ⇒ Chap. 11.2 [▶ 58].

9.3 Outside cleaning

⚠️ WARNING Risk of injury due to moisture penetration in current-carrying components

Injury by electric shock.



- ▶ Never clean electric motor or additional electrical components such as isolation switch, frequency converter, control cabinet, etc. with a water jet, pressure washer, or steam cleaner.

Procedure:

- Clean fan housing and plastic parts with a damp cloth.
⚠️ CAUTION Do not use a dry cloth (static charge).
- Contamination and dust deposits on the cooling fins and fan cowl of the electric motor are only to be removed by dry means or with a damp cloth.
- Keep the installation site of the fan clean.



Observe cleaning interval and adjust if necessary ⇒ Chap. 10.2 [▶ 54].

10 Maintenance

10.1 Safety instructions

These safety instructions warn against dangers that can arise when performing maintenance on the fan.

⚠️ WARNING Risk of injury due to maintenance work on the fan

Injuries due to electrical, mechanical, and chemical hazards.



- ▶ Control the operating condition via authorized operating personnel.
- ▶ All other maintenance work only to be performed by authorized maintenance personnel.
- ▶ An electrician is responsible for energization of the fan.

SAFETY INSTRUCTIONS

- ▶ Wear personal protective equipment.
- ▶ In the access and work areas of the maintenance work
 - eliminate trip and fall hazards,
 - ensure sufficient lighting,
 - keep clean and tidy.
- ▶ Secure the isolation switch with a personal padlock to prevent unauthorized energization until completion of the maintenance work. Hang tag on isolation switch.
- ▶ When working inside the fan, as protection from hazardous, aggressive conveyed media:
 - Shut the provided shut-off damper to the supply air duct and discharge duct.
 - Ensure that no conveyed medium can flow in.
 - If provided, drain condensate to the casing drain.
 - Be mindful of harmful deposits and condensate residue.
- ▶ When working inside the fan, ensure that the impeller is stationary and prevented from automatically being rotated by supply or discharge air.
- ▶ After completion of work
 - check functionality of all safeguards,
 - remove all tools and materials from the work area,
 - wipe up spilled substances and dispose of them properly.

⚠️ CAUTION Risk of injury due to electrostatic discharge

Subsequent injuries due to response upon being startled.



- During operation and maintenance, the impeller can build up electrostatic charge.
- Cleaning of the fan housing, impeller, and plastic parts with a dry cloth leads to electrostatic charge!
- ▶ Only clean the fan with a damp cloth.

10.2 Maintenance table



The maintenance intervals (W/weekly, M/monthly, 6M/semi-annually and 12M/annually) are to be adapted to the current operating conditions of the fan as determined by the customer.

Maintenance activity	Cross reference	W	M	6M	12M*
Check operating condition	⇒ Chap. 10.3.1 [► 55]	X			
Outside cleaning	⇒ Chap. 9.3 [► 53]		X		
Manual casing drain type K (option): drain condensate	⇒ Chap. 4.3.5 [► 25]	X			
Check automatic casing drain type V (option) and siphon	⇒ Chap. 4.3.5 [► 25] ⇒ Chap. 6.9.1 [► 39]	X	X		
Test run during extensive downtime	⇒ Chap. 8.2.3 [► 51]			X	
Inside inspection (if necessary)	⇒ Chap. 10.3.2 [► 56]			X	
Inside cleaning (if necessary)	⇒ Chap. 10.3.3 [► 56]			X	
Annual inspection	⇒ Chap. 10.3.4 [► 56]				X
Checking of electrical components by electrician	—				X

* Or before placement in service after an extensive downtime period.



An hour meter is helpful.

Record all maintenance work performed in a machine logbook. A template is available from the point of contact.

10.3 Maintenance work



For questions regarding maintenance work and intervals, contact the distributor or manufacturer. Draw up a service contract if required.

10.3.1 Check operating condition

Check during fan operation:

- Visual checks:
 - For proper mounting, damage, and contamination: Safeguards (splinter protection, protective grid with free installation, optional motor cover), fan housing, electric motor, and support.
 - For leak tightness: Sleeves, inlet cover, optional hub seal.
 - For loose screw connections.
- Smooth operation of fan: For irregular running, check for vibration or noise ⇒ Chap. 8.2.3 [► 51].
- Functionality of the V-belt drive: Check the belt tension upon irregular running, vibration, or noises ⇒ Chap. 11.12 [► 74].
- Check electric motor, casing, and hub seal (option) for possible overheating (overload).

⚠ CAUTION Risk of burn

Promptly report any defects found and have them properly rectified.

10.3.2 Inside inspection

NOTICE Risk of damage due to vibration



Material damage and production downtime, reduced service life.

- ▶ Improper use or deposits on the impeller lead to imbalance and vibration.
- ▶ Switch fan off immediately in case of unusual vibration.
- ▶ Check parts in contact with the medium.

Procedure:

- Remove sleeve from the inlet connection ⇒ Chap. 6.8 [▶ 37]. If available, insert a borescope into the gap.
- Otherwise, remove the inlet cover ⇒ Chap. 11.5 [▶ 64].
- Check impeller as well as internal housing for corrosion, stress cracks, deformations, and deposits.
- If necessary, clean the impeller and inside of the casing ⇒ Chap. 10.3.3 [▶ 56].
- Replace damaged impeller immediately. Use only genuine spare parts.

10.3.3 Inside cleaning

NOTICE Risk of damage due to aggressive cleaning agents and sharp cleaning tools



Damage to plastic surfaces.

- ▶ Select cleaning agent appropriate for conveyed medium and plastic fan material.
- ▶ If possible, use warm water and a household cleaning agent.
- ▶ Use a brush or a wooden scraper to loosen deposits.

Procedure:

- If present, first open casing drain (type K) and drain condensate into a container.
 - Loosen sleeve at inlet connection and remove ductwork end ⇒ Chap. 6.8 [▶ 37].
 - Remove the inlet cover from the casing together with the sealing ring ⇒ Chap. 11.5 [▶ 64].
 - Carefully clean impeller, inlet cover, and inside of the casing.
- NOTICE** Do not damage the impeller blades in doing so.
- If there are heavy deposits, also clean the fan connection tubes.

10.3.4 Annual inspection

The mechanical and electrical functionality of the fan are assessed in the annual inspection, and its continued operation is ensured. This also applies in the event of extensive downtime.

1. Check during outside inspection

- Cracking: Fan housing, vibration absorber
- Noise: Motor bearings
- Proper mounting and damage of: safeguards (splinter protection, protective grid, optional motor cover), and support

- Blockages in condensate drain (option) and missing water in siphon.
 - Damaged parts. Replace these parts immediately.
2. Test run
- Vibration measurement and condition check of the motor bearings.



Compare measured values with

- limit value according to table ⇒ Chap. 8.2.3 [► 51],
- information in the test report from initial commissioning.

- Replace motor bearings at the end of their service life or if they exhibit significant noise development due to bearing wear. To do this, remove the electric motor ⇒ Chap. 11.7 [► 67].



The motor bearings are lifetime lubricated ⇒ Chap. 2.2.3 [► 12]. For information on the bearing service life, see the operating instructions of the electric motor.

- V-belt drive: Check the condition of the components of the V-belt drive: Replace the flange bearings at the end of their service life or if they exhibit significant noise development due to bearing wear. Check belt tension and adjust it if necessary ⇒ Chap. 11.12 [► 74].



The flange bearings have lifetime lubrication.

- Check hub seal (option, ⇒ Chap. 4.3.12 [► 28]) for leakage.
- Measure the current draw of the electric motor. The measured value may not exceed the rated current on the nameplate.
- Measure temperature of the electric motor and compare with information in the technical data sheet.

⚠ CAUTION Risk of burn

3. Inside inspection and cleaning
- Check the impeller for deformation and for damage such as cracking and corrosion.
 - Check the V-belt drive for damage. Check belt tension and adjust it if necessary ⇒ Chap. 11.12 [► 74].
 - If necessary, conduct outside and inside cleaning.
 - Check impeller position and adjust if necessary ⇒ Chap. 11.8 [► 69].
4. Assembly and final inspection
- Proper mounting of the splinter protection ⇒ Chap. 6.4 [► 34].
 - Fixed position of all screw connections.
 - Fixed position of all fastening elements (anchors) in the foundation (baseplate).
 - Short test run, checking for vibration and noise.

11 Repair

11.1 Safety instructions

These safety instructions warn against dangers that can arise when repairing the fan.

⚠️ WARNING Risk of injury due to repair work on the fan

Injuries due to electrical, mechanical, and chemical hazards.

- ▶ Only maintenance personnel authorized by the operator as well as service personnel authorized by the distributor or manufacturer may carry out repair work.
- ▶ The same safety instructions as for maintenance work apply
⇒ Chap. 10.1 [▶ 54].
- ▶ Allow the fan to cool off with the electric motor before beginning work.
- ▶ An electrician is responsible for energization of the fan.



11.2 Fault table

Identify and rectify fan faults using this table, and enter them in the machine log-book. For further information, contact customer service (see title page).

Fault	Possible cause	Fault discovery	Remedy
No function	No electrical power.	Check phase voltage.	Check electrical installation.
Conveying capacity insufficient: operating point according to technical data sheet cannot be reached.	Incorrect direction of rotation of the impeller.	Visual inspection.	Swap phases ⇒ Chap. 7.4 [▶ 46].
	Damper valve improperly positioned.	Visual inspection.	Set damper valve to proper position.
	Pressure loss in ductwork.	Measure flow rate and pressure at the operating point.	Optimize ductwork layout.
	Inflow or outflow at the fan causes high pressure loss.		Adjust the speed for the new conditions within the limits of the intended use.
	Damper valve improperly positioned in ductwork.		Adjust the system. Observe minimum distance between fan connection and damper valve or duct bend ($L \geq 3 \times \text{duct } \varnothing$).
Drive belt slips.	Check belt tension ⇒ Chap. 11.12 [▶ 74]	Tension the drive belt ⇒ Chap. 11.11 [▶ 73]	

Fault	Possible cause	Fault discovery	Remedy
	Drive belt and belt pulleys are dirty.	Visual inspection.	Clean wedges of V-belt assembly. Clean grooves of belt pulleys.
Operating speed cannot be reached.	Faulty motor winding.	Winding measurement.	Replace electric motor ⇒ Chap. 11.7 [► 67].
	Improper phase voltage.	Measure phase voltage.	Check/replace fuses, motor connection cable, FC cable.
	Motor overload due to improperly positioned damper valve.	Measure flow rate and pressure at the operating point.	Set damper valve to proper position.
	Motor overload due to system changes.	Fan/electric motor no longer meeting the operating point.	Consult with point of contact (see title page).
FC error message.	Improper setting of motor characteristics, start/stop ramps, acceleration/braking time.	FC display: check relevant parameters.	Set parameters properly ⇒ Chap. 7.3.2 [► 45].
FC error message. No acceleration from low frequency.	FC current limits are exceeded due to insufficient power factor ($\cos \varphi$).	FC current limits too low?	Adjust FC parameter "Motor characteristic" (torque quadratic to speed) ⇒ Chap. 7.3 [► 43].
	Improper motor and/or FC size.	Motor and/or FC too small?	Design FC according to motor ⇒ Chap. 7.3 [► 43].
	Start ramp too steep or acceleration time too short.	Check FC parameters.	Adjust start ramp. Increase acceleration time.
Motor protection switch or FC switches off.	Improper setting.	Measure current draw.	Set motor protection switch properly ⇒ Chap. 7.2.2 [► 42].
		Check FC parameters.	Parameterize FC properly.
	Faulty motor connection.	Measure current draw.	Check motor connection (star/delta) ⇒ Chap. 7.4 [► 46].

Fault	Possible cause	Fault discovery	Remedy
	Impeller stiff or stopped.	Visual inspection.	Remove deposits or foreign objects ⇒ Chap. 10.3.3 [▶ 56].
	Winding damage on the electric motor.	Winding measurement.	Repair or replace electric motor ⇒ Chap. 11.7 [▶ 67].
	Electric motor bearing damage.	Turn electric motor by hand.	Check EMC guidelines.
	Damaged cable, faulty cable connection.	Measurement, visual inspection.	Replace cable.
Strong vibration.	Deposits on impeller, imbalance.	Visual inspection, vibration measurement.	Clean impeller ⇒ Chap. 10.3.3 [▶ 56]. Balance impeller.
			Adjust cleaning interval.
	Damaged or malformed impeller due to (prohibited) conveyed medium.	Visual inspection.	Replace impeller ⇒ Chap. 11.5 [▶ 64].
		Points to observe: ⇒ Chap. 2.2.1 [▶ 9] and ⇒ Chap. 2.2.2 [▶ 11].	Clarify composition of conveyed medium and plastic resistance.
		Measure temperature of the conveyed medium.	Adjust operating conditions to intended use ⇒ Chap. 2.2.1 [▶ 9].
	Check operating point.		
	Check environmental conditions.		
	Ductwork connected directly to fan casing.	Adjust connection (sleeve) and ductwork distance appropriately ⇒ Chap. 6.8 [▶ 37].	
Change in length of ductwork due to thermal expansion.			
Loose impeller.	Can the impeller be moved axially on the motor shaft?	Adjust impeller position ⇒ Chap. 11.8 [▶ 69] Clamp down clamping adapter ⇒ Chap. 11.5 [▶ 64].	

Fault	Possible cause	Fault discovery	Remedy
	Impeller dips into condensate at bottom of casing.	Type K: Visual inspection.	Drain condensate ⇒ Chap. 4.3.5 [▶ 25].
		Type V: Visual inspection.	Clean and replace condensate drain/siphon ⇒ Chap. 4.3.5 [▶ 25].
		-	Retrofit with casing drain.
	Loose/defective vibration absorbers or fastening elements.	Visual inspection.	Tightly screw/replace vibration absorbers ⇒ Chap. 6.5 [▶ 35] and following.
	Improper mounting.	Installation location requirements met ⇒ Chap. 6.2 [▶ 32].	Fortify foundation (baseplate). Resize fastening elements (anchors).
	V-belt drive misaligned.	Visual inspection.	Check alignment and belt tension ⇒ Chap. 11.12 [▶ 74].
Overheating of electric motor.	Bearing or winding damage.	Auditory inspection, current draw measurement, winding measurement.	Repair or replace electric motor ⇒ Chap. 11.7 [▶ 67].
	Impeller stiff or stopped.	Visual inspection.	Remove deposits or foreign objects ⇒ Chap. 10.3.3 [▶ 56].
	Motor overload due to improperly positioned damper valve.	Measure flow rate and pressure at the operating point.	Set damper valve to proper position.
	Motor overload due to system changes.	Fan/electric motor no longer meeting the operating point.	Consult with point of contact (see title page).
	FC does not reach required voltage.	Check FC.	Use a suitable FC.
Prohibited operating conditions.	Ductwork not leak tight.	Check for leakage.	Seal up.
	Loose hose clamps or damaged sleeves.		Re-tighten hose clamps or replace sleeves ⇒ Chap. 6.8 [▶ 37].

Fault	Possible cause	Fault discovery	Remedy
	FC parameter "max. frequency" set improperly (speed too high, overheating of electric motor).	Check FC parameters ⇒ Chap. 7.3.2 [▶ 45].	Adjust parameters according to characteristic map in technical data sheet.
Grinding noise coming from the impeller.	Casing too tight.	Check distance and alignment of ductwork to fan connection.	Adjust ductwork distance and connection (sleeves) appropriately.
	Ductwork connected to fan without sleeves.		Connect ductwork to fan with sleeves ⇒ Chap. 6.8 [▶ 37].
	Impeller misaligned.	Can the impeller be moved axially on the motor shaft?	Impeller position ⇒ Chap. 11.8 [▶ 69] Clamp down clamping adapter ⇒ Chap. 11.5 [▶ 64].
	Deposits or foreign objects between impeller and inlet cover.	Determine grinding point. Check with feeler gauge.	Remove deposits or foreign objects ⇒ Chap. 10.3.3 [▶ 56].
	Impeller defect.	Visual inspection.	Replace impeller ⇒ Chap. 11.5 [▶ 64].
Audible sound from bearings.	Bearing damage.	Auditory inspection.	Replace motor bearings or exchange motor ⇒ Chap. 11.7 [▶ 67].
	End of service life reached.		
	Bearing damage due to electrical discharge machining (bearing currents).	Measure voltage between the motor shaft and casing of the electric motor.	Interference suppression measures with FC operation; see FC manufacturer's guidance. Check EMC guidelines. Use current-insulated roller bearings or ceramic hybrid bearings.
Excessive leakage at impeller hub.	Overpressure operation of the fan (without optional hub seal).	Pressure measurement.	Operate fan at negative pressure.
			Install optional hub seal.

Fault	Possible cause	Fault discovery	Remedy
	Hub seal worn or defective.	Visual inspection.	Replace sealing ⇒ Chap. 11.10 [▶ 72]
Drive belt torn or damaged.	Normal wear	Visual inspection.	Replace severely damaged drive belt ⇒ Chap. 11.11 [▶ 73]
	Drive belt tension too high.	Check tension, alignment, and condition of drive belt.	Replace severely damaged drive belt. Tension drive belt properly ⇒ Chap. 11.12 [▶ 74]

11.3 Spare parts and wear parts

⚠ DANGER Risk of injury due to impeller explosion

Serious injuries due to debris being launched out.

- Prohibited spare parts.
- ▶ Only use an original impeller from the manufacturer as a spare part.

NOTICE Risk of damage due to prohibited spare parts

Component and material damage as well as production downtime.

- Invalidation of warranty.
- ▶ Only use original spare parts from the manufacturer for maintenance activities and repairs.

Order spare parts and wear parts from customer service (see title page) in a timely manner with the following information:

- Type classification of fan according to nameplate or technical data sheet.
- Desired quantity.
- Specific designation
 - of the spare part or wear part ⇒ Chap. 4.1 [▶ 22],
 - of the option or accessory ⇒ Chap. 4.3 [▶ 24].

Have spare parts and wear parts for the impeller or hub seal available:

Pc.	Designation	Spare part	Wear part
1	Impeller	X	
1	Hub cap	X	
1	Clamping adapter	X	
1	Sealing ring (inlet cover)	X	
1	Hub seal (option)		X

Pc.	Designation	Spare part	Wear part
1	Drive belt and belt pulleys for belt drive		X



A new hub cap is also required to set the impeller position ⇒ Chap. 11.8 [► 69].

11.4 Preparation for repairs

Prepare the fan for repairs (impeller, electric motor, hub seal, etc.) as follows:

1. Observe safety instructions ⇒ Chap. 10.1 [► 54].
2. Switch off the fan and FC (option) and use the isolation switch to remove voltage on all phases.
3. Secure the isolation switch with a personal padlock to prevent unauthorized energization until completion of the repair work. Hang tag on isolation switch.
4. Shut the shut-off damper to the supply air duct and discharge duct.
5. Drain condensate to condensate drain type K (option).
6. Only for removal of the casing: Remove or disconnect the drain pipe to the siphon from the condensate drain type V (option).
7. Loosen sleeves on inlet and outlet connections.
8. Remove removable duct section from inlet connection ⇒ Chap. 6.8 [► 37].



Risk of contamination of the ductwork

Cover open ductwork ends with plastic sheeting during repairs.

11.5 Impeller exchange

Conditions:

- Fan has been prepared for repairs ⇒ Chap. 11.4 [► 64].

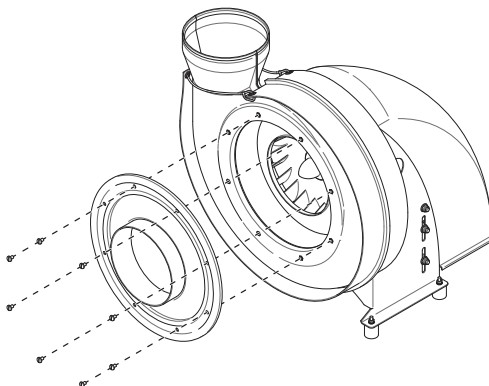
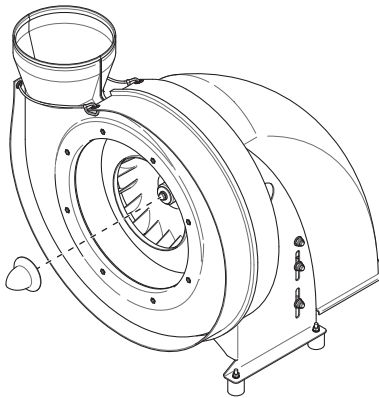

Fig. 34: Removing inlet cover

Procedure:

- Remove splinter protection.
 - Remove snap hooks.
- Loosen fastening screws on inlet cover.
- Carefully remove inlet cover from casing.

NOTICE The sealing ring can stick to the casing and become damaged.
- Remove sealing ring.



- Cut out and remove hub cap with appropriate tools.
 - The hub cap cannot be removed non-destructively - order spare part in a timely manner.

NOTICE Do not reuse hub cap that has been removed! Only a leak-proof, undamaged hub cap prevents aggressive conveyed media from corroding the motor shaft and impeller hub, which could destroy the impeller.

Fig. 35: Removing hub cap

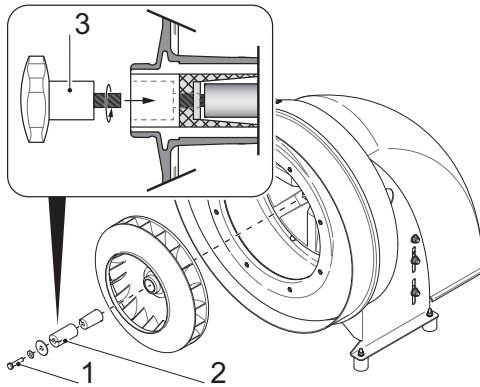

- Loosen clamping adapter.
 - Loosen and remove fastening screw (1).
 - Pull outer cone (2) from the motor shaft with a suitable release bolt (3) (see detail).
- Remove impeller and clamping adapter from motor shaft.

Fig. 36: Removing impeller



The impeller is mounted directly to the motor shaft on fans CMVeco 125-200 with electric motors of size 100 or 112 as well as for CMVeco 250-400 with electric motors of size 132.

Mounting instructions

- For slip-free power transmission, the following shall be free of grease:
 - Flange bearing shaft (BD).
 - Impeller borehole.
 - The outside of the clamping adapter borehole.
- **NOTICE** Risk of bearing damage! Never strike the motor shaft when mounting the impeller.
- Set impeller position ⇒ Chap. 11.8 [► 69].
- Mount clamping adapter:
 - Nest cones together such that the slots do not overlap.

- Tighten fastening screws, with RIPP LOCK® for fastener security, according to the following table:

Fan/size	Fastener threads	Max. tightening torque [Nm]
CMVeco 125/125	M4	6
CMVeco 160/160	M5	8
CMVeco 200/180	M6	15
CMVeco 200/200	M6	15
CMVeco 250/225	M8	20
CMVeco 250/250	M8	20
CMVeco 315/280	M10	20
CMVeco 315/315	M10	20
CMVeco 400/400	M12	25

- Check impeller mobility.
 - NOTICE** The impeller may not grind.
- Heat new hub cap evenly to approx. 60 °C with hot air blower and press onto hub. Check mounted hub cap for cracks and damage.
- Inspect the sealing ring of the inlet cover for damage before installation and replace if necessary.
- Tighten the fastening screws of the inlet cover according to the table:

Fan/size	Fastener threads	Max. tightening torque [Nm]
CMVeco 125-400	M8	5

- Conduct a test run after repair ⇒ Chap. 8.2.3 [► 51].

11.6 Casing exchange

Conditions:

- Fan has been prepared for repairs ⇒ Chap. 11.4 [► 64].
- Impeller has been removed ⇒ Chap. 11.5 [► 64].

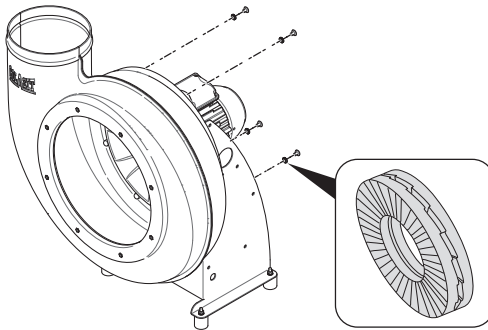

Procedure:

- Loosen and remove fastening screws and corresponding wedge-lock washers (Nord-Lock, see detail) from the back of the support.
- Remove casing from support.

Fig. 37: Removing casing

Mounting instructions

- Reinstall hub seal (option) ⇒ Chap. 11.10 [► 72].
- Align casing opening to the center of the motor shaft.
- **NOTICE** Secure the fastening screws of the casing
 - with wedge-lock washers (mandatory; Nord-Lock, see detail). Do not use threadlocker (Loctite)!
 - to the tightening torque specified in the following table.

Fan/size	Fastener threads	Max. tightening torque [Nm]
CMVeco 125-400	M8	5

11.7 Electric motor exchange

Conditions:

- Fan has been prepared for repairs ⇒ Chap. 11.4 [► 64].

Removing the electric motor (BD)

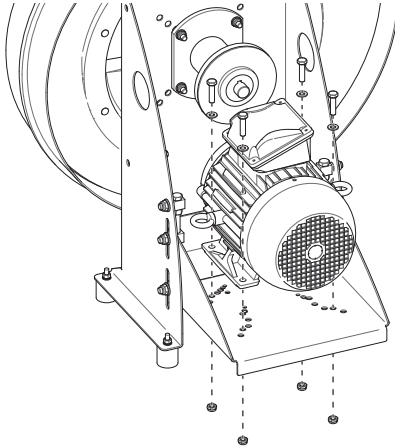

Fig. 38: Removing the electric motor (BD)

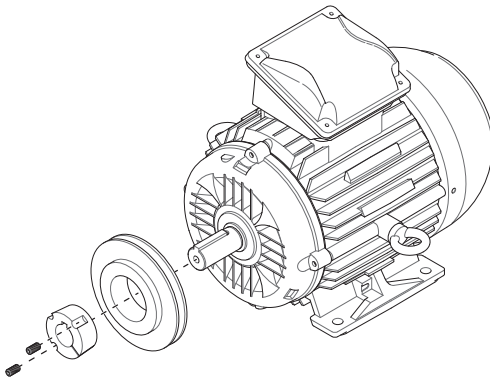

Fig. 39: Removing the belt pulley from the motor shaft (BD)

Mounting instructions

NOTICE Risk of damage to the electric motor

Damaged motor bearings.

- ▶ Protect the motor shaft/bearings from being hit during transport and mounting of the electric motor.
- ▶ Observe the instructions in the manual from the motor manufacturer.
 - Fasten mounting nuts according to the following table.
 - The thread is based on the motor size.

Procedure:

1. Remove all cables from the terminal box of the electric motor and protect from damage.
2. Support and secure the electric motor with suitable supports.
3. Tension the belt: Loosen the fastening screws of the motor bracket on the support and screw in the threaded rods
⇒ Chap. 11.11 [▶ 73].
4. Loosen the mounting nuts on the motor bracket.
5. Remove the belt pulley with the taper lock bushing from the motor shaft and reuse them for the new electric motor.
6. Move a heavy electric motor with suitable hoisting gear. Use the lifting eye bolts on the electric motor for this purpose.
7. Install the new electric motor.
8. Align and tension the belt
⇒ Chap. 11.12 [▶ 74].



Thread	Max. tightening torque [Nm]
M8	22
M10	45
M12	80
M16	190

- Connect electric motor ⇒ Chap. 7.4 [▶ 46].
- Check motor rotation direction ⇒ Chap. 8.2.1 [▶ 50].
- Conduct test run ⇒ Chap. 8.2.3 [▶ 51].

11.8 Measuring and setting impeller position

NOTICE Risk of damage due to grinding impeller

Damage to impeller.

- ▶ Set the impeller position using distance X specified in the table.
- ▶ Conduct measurement checks periodically.
- ▶ Determine grinding point.

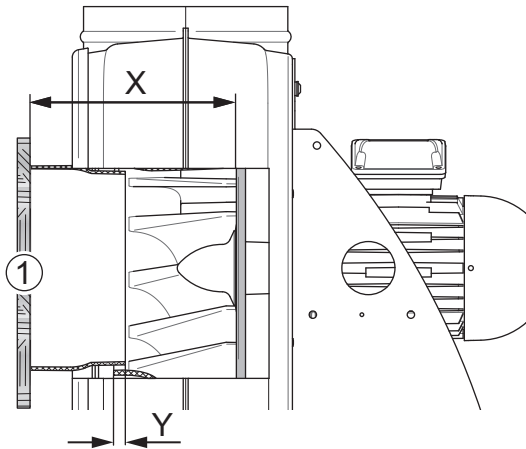

Fig. 40: Measuring impeller position (sectional view)

The overlap Y of the inlet cover taper and the impeller cannot be measured directly. Instead, the distance X from the inlet connection to the impeller support disc is measured according to the table below.



As an aid, place a wooden board (1, see illustration) across the inlet connection.

Fan/size	Distance X [mm]	Overlap Y [mm]
CMVeco 125/125	125	3

Fan/size	Distance X [mm]	Overlap Y [mm]
CMVeco 160/160	144	2
CMVeco 200/180	195	No overlap, gap 5 to 20 mm
CMVeco 200/200	189	1
CMVeco 250/225	229	No overlap, gap 5 to 20 mm
CMVeco 250/250	220	4
CMVeco 315/280	310	No overlap, gap 5 to 20 mm
CMVeco 315/315	304	1
CMVeco 400/400	323	5

Procedure:

1. Prepare fan for measurement:
 - Loosen sleeve at the inlet connection.
 - Remove ductwork end at the inlet connection.
2. Conduct measurement according to figure 39.
3. Compare distance X with value from table.

Set impeller position:

1. Remove inlet cover and hub cap.
2. Loosen clamping adapter.
3. Temporarily mount the inlet cover for alignment.
4. Push impeller onto motor shaft to distance X specified in the table.
5. Tighten clamping adapter to specified tightening torque.
6. Check impeller mobility.
7. Press new hub cap onto hub.
8. Assemble fan.
9. Conduct test run ⇒ Chap. 8.2.3 [► 51].



For necessary removal and mounting work, see ⇒ Chap. 11.5 [► 64] for mounting instructions.

11.9 Replacing the V-ring seal (option)

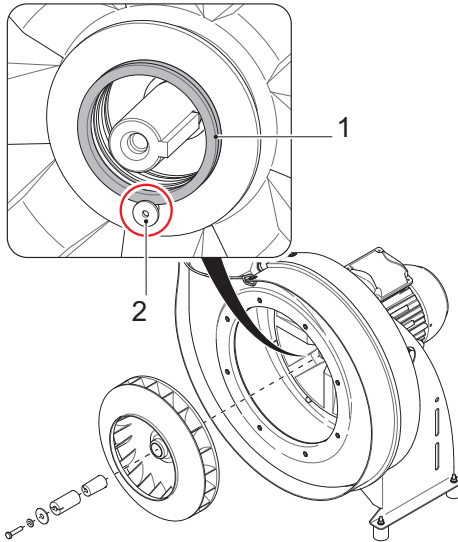

Fig. 41: Replacing the V-ring seal

Conditions:

- Impeller has been removed
⇒ Chap. 11.5 [► 64].
- Casing is mounted and is centered with the shaft of the flange bearing.

Procedure:

1. Remove the V-ring seal (1) (see detail).

2. Install a new V-ring seal.

NOTICE The V-ring seal must be captured under the guide button (2).

3. Mount the clamping adapter and impeller on the motor shaft.



Important

The impeller should turn freely by hand after mounting.

4. Assemble the fan ⇒ Chap. 11.5 [► 64] (see mounting instructions).



Check identical axial alignment of the impeller.

5. Conduct test run (min. 1 h) ⇒ Chap. 8.2.3 [► 51].

11.10 Hub seal (option) felt ring replacement

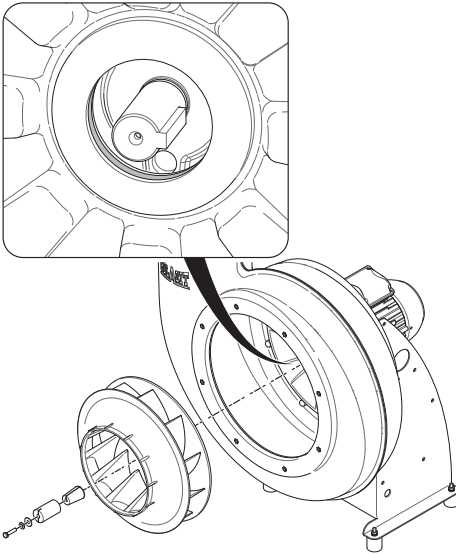

Fig. 42: Replacing the felt ring of the hub seal

Conditions:

- Impeller has been removed
⇒ Chap. 11.5 [► 64].
- Casing is mounted and is centered with the motor shaft.

Procedure:

1. Remove felt ring with tweezers (see detail).
2. Saturate the new felt ring soak with lubricant.
Lubricant: Interflon Lube TF (aerosol)
3. Mount felt ring.
NOTICE The felt ring may not protrude into the casing.
4. Mount the clamping adapter and impeller on the motor shaft.



Important

The impeller should turn freely by hand after mounting.

5. Allow the felt ring to run for one minute at a maximum of 1500 rpm.

NOTICE Risk of damage to the fan

Smoke and chips can develop for a short time while running.

- If this happens, remove the impeller and clean the hub.

6. Assemble the fan ⇒ Chap. 11.5 [► 64] – see mounting instructions.



Check identical axial alignment of the impeller.

7. Conduct test run (min. 1 h) ⇒ Chap. 8.2.3 [► 51].

11.11 Replacing the drive belt

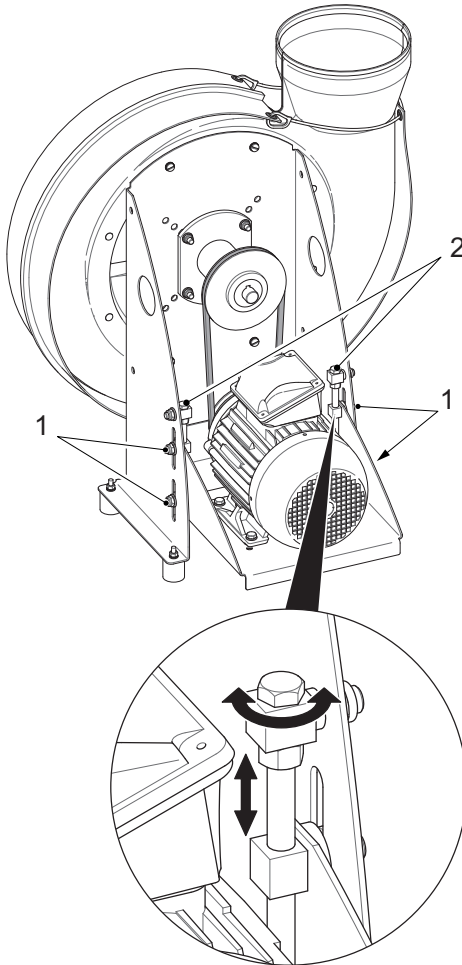

Conditions:

- The hood is removed.

Procedure:

1. Relieve the tension on the drive belt: Loosen the fastening screws of the motor bracket on the support (1) and screw in the threaded rods (2, see detail).

2. Replace the drive belt.

NOTICE Use an identical drive belt. Check the belt type and belt length.

NOTICE Check the belt pulleys. Replace them if they are worn.

3. Tension the drive belt using the two threaded rods.

4. Conduct test run
⇒ Chap. 8.2.3 [► 51].

Fig. 43: Replacing the drive belt

Checking the belt tension after placement in service and test run



It is recommended to check the belt tension after a brief runtime (compensation for initial elongation). Inspection intervals of 3 to 6 months, based on load, are then recommended.

11.12 Measuring and setting belt tension

The belt tension (S) is to be set in accordance with the belt plate

⇒ Chap. 4.2 [▶ 23].

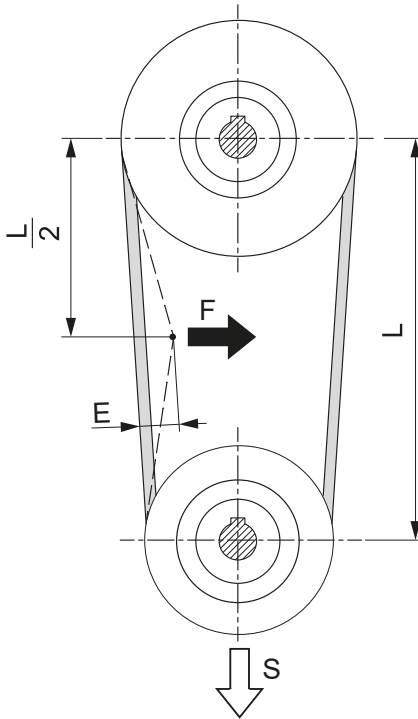

Procedure:

- Determine the frequency at the center of the belt span (approx. $L/2$) using a belt frequency meter and compare it with the value specified on the belt plate.
- Optional: Apply the specified test force (F) at the center of the belt span and measure the indentation depth (E). Compare the measured value with the value specified on the belt plate.
- Tension the drive belt if necessary until the specified value is reached.

Fig. 44: Measuring belt tension



The belt span is the free section of belt between two belt pulleys that is not resting on the pulleys.

12 Removal from service, disposal, and recycling

12.1 Safety instructions

These safety instructions warn against dangers that can arise during removal from service and disposal of the fan.

⚠️ WARNING Risk of injury during removal from service and disposal of the fan

Injuries due to electrical, mechanical, and chemical hazards.



- ▶ An electrician is responsible for removal of the power supply from all phases.
- ▶ Removal of the fan to be completed only by authorized mounting personnel.
- ▶ Removal for disposal is to be completed only by authorized transport personnel.

12.2 Environmental protection

📄 NOTICE Environmental hazards upon disposal of the fan

Water and soil pollution



- Check the fan for conveyed medium deposits that are harmful to health and the environment.
- ▶ Dispose of contaminated components such as casing and impeller as special waste.

Housing and impeller can be made of different plastics.



For proper recycling, an abbreviation of the plastic type is indicated on the impeller, inlet cover, and casing.

12.3 Removal from service

⚠️ WARNING Risk of injury due to improper removal

Injuries by pinching and crushing of body parts.



- ▶ Wear protective equipment.
- ▶ Safeguard work area and prevent unauthorized access using enclosures, safety nets, etc.
- ▶ Secure a fan that is mounted on the wall or ceiling against falling or tipping over by attaching suitable supports.
- ▶ Provide suitable transport aids for transportation of the fan.

⚠️ WARNING Risk of injury due to escape or inflow of a conveyed medium with the ability to cause adverse health effects

Risk of eye irritation, cough, difficulty breathing, burn, and suffocation.



- ▶ Wear protective equipment.
- ▶ Close shut-off damper to inlet and outlet connections.
- ▶ Watch for deposits and condensate of the conveyed medium in the fan and ductwork.

Procedure:

- Switch off fan and FC (option) and prepare them for removal:
 - Allow to cool down.

- Close shut-off dampers in supply air and discharge air ductwork.
- Drain and dispose of condensate in the condensate drain (option).
- To be completed by electrician:
 - Switch off higher-level control and FC.
 - Secure isolation switch with a personal padlock to prevent unauthorized energization and hang tag.
 - Remove power to the fan and additional electrical components on all phases, and disconnect the electrical connection.
- Remove piping and ductwork connections:
 - Disconnect the drain pipe to the siphon from casing drain type V (option).
 - Remove sleeves on inlet and outlet connections.
- Loosen threaded fasteners for the vibration absorbers on the support.
- Prepare fan for disposal in a location suitable for this purpose.

12.4 Disposal instructions

When disposing of the fan, observe all nationally applicable regulations and legal requirements for waste disposal, and comply with regional environmental protection regulations.

Preferably, commission a waste disposal company for proper recycling or disposal.

Disassembly instructions

- Separate the fan components into material groups and dispose of them separately:
 - Metals
 - Plastics
 - Electrical components



Dispose of plastic parts contaminated by conveyed media that are harmful to health and the environment as special waste.

13 EU - Declaration of conformity

We, the manufacturer

COLASIT AG
 Faulenbachweg 63
 3700 Spiez
 Switzerland

declare under our sole responsibility
 that the product of the series
 CMVeco 125-400 with V-belt drive

Plastic industrial fan
 CMVeco 125/125
 CMVeco 160/160
 CMVeco 200/180
 CMVeco 200/200
 CMVeco 250/225
 CMVeco 250/250
 CMVeco 315/280
 CMVeco 315/315
 CMVeco 400/400

to which this declaration refers is in conformity with the provisions of the following EU directives and harmonized standards as of the date of issue stated:

EU Directives	Machinery Directive 2006/42/EC
	EMC Directive 2014/30/EU
Harmonized standards	EN ISO 12100: 2011
	EN ISO 12499: 2008
	EN 60204-1: 2019
	EN IEC 61000-6-4:2019
Name and address of the document manager	Andreas Roth COLASIT AG Faulenbachweg 63 3700 Spiez Switzerland

Spiez, 6/7/2023



B. Stucki (Division manager)

Index

- A**
- Anchoring elements 36
 - Annual inspection 55, 56
 - Application limits 12
 - Attachment points 29
- B**
- Balanced 22
 - Bearing damage 19, 30
 - Bearing damage. 60
 - Bearing service life 57
 - Bracing angle 36
- C**
- Cable strain relief 49
 - Casing drain 12, 25, 39, 54, 55, 56, 61
 - Ceiling mounting 32
 - Center of gravity 29
 - Centrifugal fan 7, 23, 43
 - Chain sling 31
 - Claims for damages 30
 - Clamping adapter 22, 60, 62, 65
 - Collecting container 39
 - Complaint 29
 - Complaint period 30
 - Complaints 30
 - Condensate drain 25, 39, 40, 57, 61, 64, 76
 - Condensation 30
 - Connection thread 35
 - Connection tube 22
 - Cracking 38, 56, 57
 - Crane hook 30
- D**
- Damper valve 50, 58, 59, 61
 - Danger to life 16, 18, 29, 41
 - Degree of protection 27
 - Direction of rotation arrow 50
 - Disposable packing 30
 - Disposal 7, 14, 75, 76
 - Disposal instructions 30, 76
 - Drain pipe 39
- Drive belt 73
 - Duct misalignment 38
 - Duct section 38, 64
 - Ductwork 10, 11, 13, 20, 24, 25, 37, 40, 58, 60, 62, 64
 - Ductwork end 38, 56, 70
- E**
- EC motor 43
 - Electrician 14, 15, 18, 41, 50, 54, 55, 58, 75, 76
 - Electromagnetic fields 19
 - Entry protection 27
 - Environmental damage 39
 - Eyelets 34
- F**
- False air 40
 - Fan cowl 33, 53
 - Fan housing 19, 21, 24, 37, 50, 53, 55, 56
 - Fan impeller 50
 - Fan size 38
 - Fan support 36
 - Fastening elements 32, 36, 40, 57, 61
 - FC parameterization 26
 - Felt ring 28, 72
 - Fire extinguishers 19, 21
 - Flange connections 25
 - Floor load 32
 - Floor mounting 35
 - Floor opening 40
 - Forklift 31
 - Forks 31
 - Forward-curved impeller blades 22
 - Foundation (baseplate) 32, 35, 40, 57, 61
 - Free sucking 20, 27, 50
 - Frost-resistant 40
- H**
- Health protection 13
 - Hoisting gear 29, 30, 68
 - Hole pattern 35
 - Hose clamps 24, 38, 61

Hub cap	22, 65, 66, 70
Hub seal	11, 13, 28, 55, 57, 63, 64, 67
Humidity	30

I

IM motor	43
Impeller breakage	22
Impeller position	57, 60, 62, 64, 65, 69
Incoming goods inspection	29
Inflow	13, 20, 32, 54, 75
Inlet connection	12, 22, 23, 38, 56, 64, 69, 70
Inlet cover	22, 64, 75
Inside cleaning	55, 56, 57
Installation height	39, 40
Installation location	13, 14, 30, 32, 35, 36, 47, 61
Installation position	35
Installation site	32, 53
Intermediate storage	30
Isolation switch	8, 18, 21, 26, 41, 46, 47, 48, 50, 53, 54, 64, 76

L

Lateral forces	38
Leakage current	19
Lifting eye bolt	29, 30, 31
Lifting eye bolts	68
Load	29
Load capacity	32, 35
Load handling attachments	30

M

Mains voltage	42, 47, 48
Maintenance	13, 14, 15, 52, 54
Maintenance intervals	13, 54
Maintenance opening	22
Maintenance personnel	15, 54, 58
Maintenance switch	26
Maintenance work	11, 35, 54, 55, 58
Material damage	7, 9, 11, 16, 29, 32, 35, 50, 56, 63
Minimum distance	19, 33, 58
Misuse	11
Motor	11, 35
Motor axis	23

Motor bearings	12, 42, 57, 68
Motor cover	55, 56
Motor nameplate	47, 48, 51
Motor rotation direction	50
Motor shaft	22, 60, 62, 65, 68, 70
Mounting personnel	14, 15, 50
Mounting position	37, 39
Mounting residues	38
Mounting surface	32, 40

N

Nameplate	10, 42, 45, 57, 63
Negative pressure operation	40
Nominal speed	26

O

OFF position	26
Operating conditions	10, 12, 54, 60
Operating faults	19, 24, 53
Operating personnel	15, 53, 54
Operating temperature	10, 12
Operator	7, 9, 10, 13, 14, 17, 21, 42, 58
Original packaging	30
Outlet connection	11, 12, 22, 23, 25, 27, 32, 40, 50, 64, 75
Outside cleaning	15, 55
Overheating	55
Overload	42
Overpressure	13, 28

P

Package	29, 30, 31
Packing	30
Padlock	18, 26, 50, 54, 64, 76
Pallet stacker	31
Personal padlock	18, 50, 54, 64, 76
Piping	76
PM motor	43, 45
Potentiometer	26, 51
Production downtime	32, 35, 56, 63
Protective devices	20, 48, 54
Protective earthing	48
Protective equipment	13, 14, 17, 18, 20, 29, 32, 54, 75
Protective grid	11, 20, 27, 55, 56
PVC	21

R	
Regulations	13, 29, 41, 76
Repair work	15, 18, 26, 33, 38, 41, 58, 64
Return shipment	30
Round isolators	35
Rubber band	34
S	
Safeguards	13
Safety instructions	29, 54, 58, 64
Safety protection	27
Screw connections	36, 40, 55, 57
Sealing ring	22, 48, 56, 64
Service openings	32, 40
Shipping documents	29
Shore hardness	35
Short circuit	18, 19
Shut-off damper	20, 32, 40, 54, 64, 75
Signs	23
Siphon	12, 25, 39, 55, 57, 61, 64, 76
Siphon height	40
Siphon overflow	40
Sleeve	12, 22, 38, 56, 70
Sling	29, 30, 31
Smooth running	38
Snap hooks	34, 64
Spare parts	12, 63
Specification sheet	8, 9, 10
Speed adjustment	26
Speed control	26
Splinter protection	11, 20, 22, 34, 39, 40, 55, 56, 64
Start-up	18, 20
Storage temperature	30
Supplier's instructions	36
Supply air duct	50, 54, 64
Support	19, 22, 31, 32, 36, 41, 44, 48, 55, 56, 67, 75, 76
Support braces	36
Supports	38
Swinging movements	29
T	
Terminal	12
Terms and conditions	30
Test report	52, 57
Test run	51, 55, 57, 66, 69, 70
Total weight	
Total weight	35
Toxic condensate	39
Transport aids	29
Transport damage	29, 30
Transport paperwork	29
Transport personnel	14, 75
Transport protection	29
Transport route	29
V	
Vibration	11, 22, 24, 35, 47, 51, 52, 55, 56, 60
Vibration resistant	32
V-ring seal	71
W	
Wall bracket	24, 27, 32, 36, 37
Wall mounting	24, 27, 35, 36
Warning symbols	16
Wear part	28, 63
Welding edge	34
Wellflex sleeves	38
Work area	20, 32, 33, 54, 75



Innovative technology for the sake of the environment

- since 1945 -

When it comes to thermoplastics, Colasit AG is one of the world's leading brands in fan and system engineering. Our qualified staff impress with technical expertise and great dedication, guaranteeing you the highest quality on all five continents.

We set our targets high to see all our projects through to success and complete every job to your complete satisfaction. We combine tradition and innovation – our many years of experience are a foundational component of our work, just as is the incorporation of the latest technology.

Place your trust in us – we accompany you throughout all phases of your project, starting from planning with the manufacturer all the way down to commissioning.

